

# 3663339COM 6 Drawer Dresser



Date of Purchase \_\_\_ / \_\_\_ / \_\_\_  
Lot Number:

B343663339COM0



**Do Not Return This Product!**  
Contact our customer service team for help first.  
**Call:** 1-800-489-3351 (toll free)  
Monday-Friday 9am - 5pm CST  
**Visit:** [www.ameriwoodhome.com](http://www.ameriwoodhome.com)

THIS INSTRUCTION BOOKLET CONTAINS **IMPORTANT** SAFETY INFORMATION. PLEASE READ AND KEEP FOR FUTURE REFERENCE.

## Secure Your Furniture

Keep your home and family safe with the wall anchor kit that is included with the product.

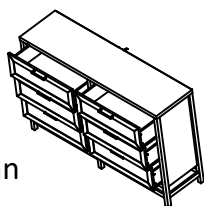

Serious or fatal crushing injuries can occur from tipping furniture.

**WARNING:** Manufacturer assumes no liability for improper installation or excessive loads placed on screws or bracket. This wall anchor is not a substitute for proper adult supervision.



Follow Ameriwood Home



# Contact Us!

## Do NOT return this product!

Contact our friendly customer service team first for help.

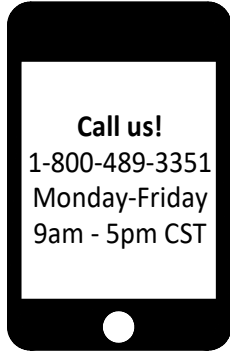

Visit [ameriwoodhome.com](http://ameriwoodhome.com) to view the limited warranty valid in the U.S. and Canada.

Assembly Tips



# Helpful Hints

PEOPLE NEEDED FOR ASSEMBLY: 1-2

- Open your item in the area you plan to keep it to avoid excessive heavy lifting.
- Identify, sort and count the parts before attempting assembly.
- Compression dowels are lightly tapped in with a hammer.
- Slides are labeled with a **R** (right) and **L** (left) for proper placement.
- Make sure to always face the point on the top of the Cam Lock towards the outer edge.
- Use all the nails provided for the back panel and spread them out equally.
- Back panel must be used to make sure your unit is sturdy.
- Do NOT use harsh chemicals or abrasive cleaners on this item.
- Never push, pull, or drag your furniture.

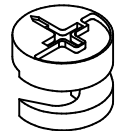

## Before You Start

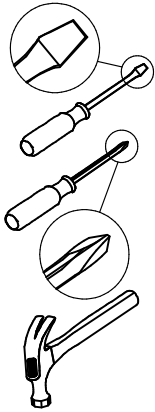
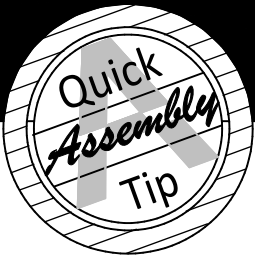

- ✓ Read through each step carefully and follow the proper order
- ✓ Separate and count all your parts and hardware  
Parts are labeled on the surface or edge of the part
- ✓ Give yourself enough room for the assembly process
- ✓ Have the following tools: Flat Head Screwdriver, #2 Phillips Head Screwdriver and Hammer
- ✓ Caution: If using a power drill or power screwdriver for screwing, please be aware to slow down and stop when screw is tight. Failure to do so may result in stripping the screw.

## Cam Lock Fastening System

This Cam Lock Fastening System will be used throughout the assembly process.

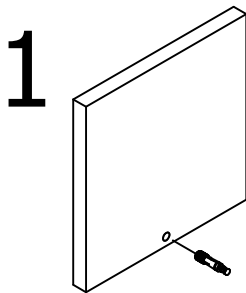

1 Press CAM BOLT into hole.

2

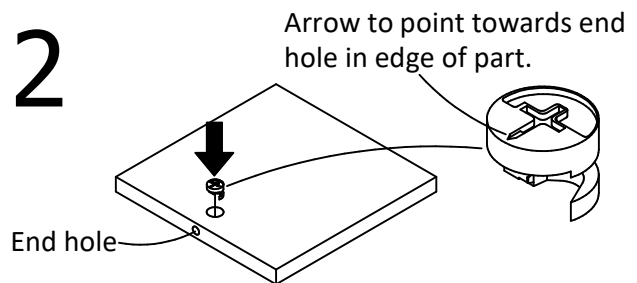

Press CAM LOCK into hole.

3

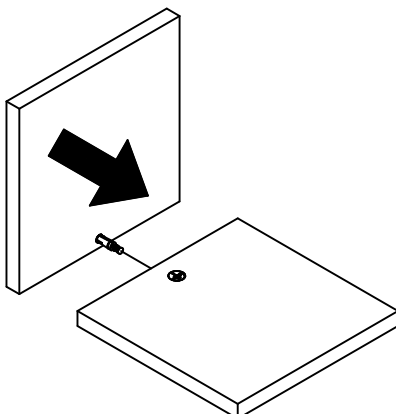

Press parts together so CAM BOLT inserts into edge hole.

4

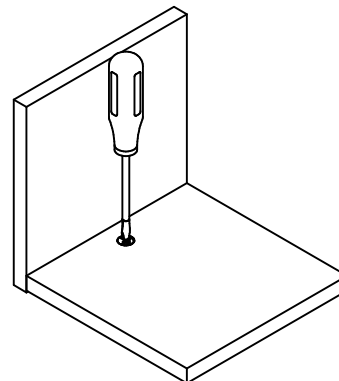

Using a screwdriver, turn the CAM LOCK clockwise to lock the CAM LOCK and CAM BOLT into their holes and fastening parts together.

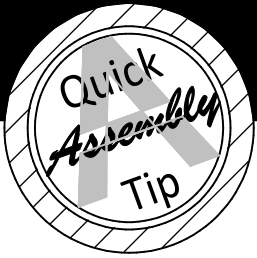

# Before You Start

Please Note:

You may need to lightly tap the wood dowels into the holes during your assembly process.

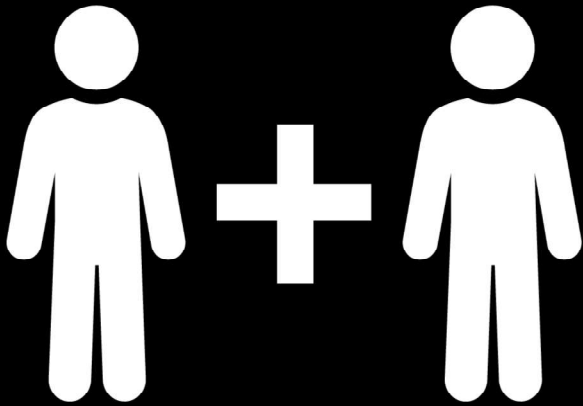
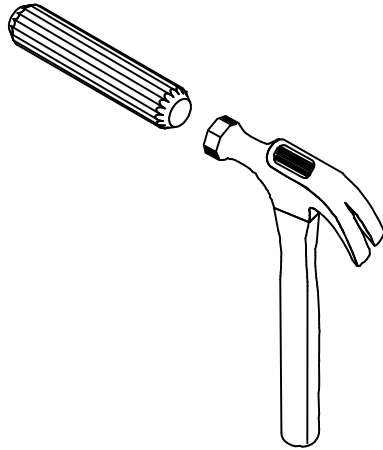

**2 PEOPLE NEEDED FOR ASSEMBLY**

**2 PERSONAS NECESITADAS  
PARA LA ASAMBLEA**

**2 PERSONNES NÉCESSAIRES  
POUR L'ASSEMBLAGE**

**CAUTION:** Failure to use 2 people for assembly could result in unit damage or personal injury.

**PRECAUCIÓN:** Si no se utilizan 2 personas para el ensamblaje, se pueden producir daños en la unidad o lesiones personales.

**ATTENTION:** Échec d'utiliser 2 personnes pour l'assemblage peut causer du dommage au meuble ou causer des blessures.

# Board Identification

Not actual size

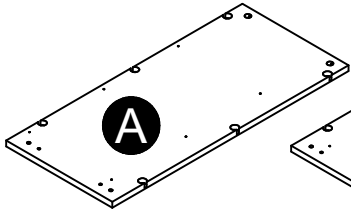

Left Panel  
33663339010

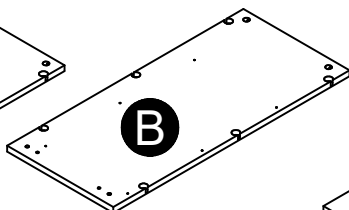

Right Panel  
33663339020

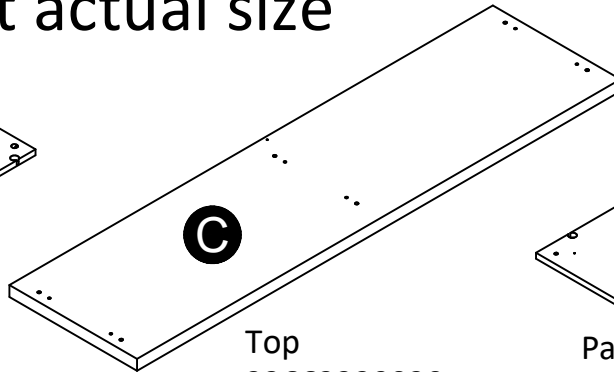

Top  
33663339030

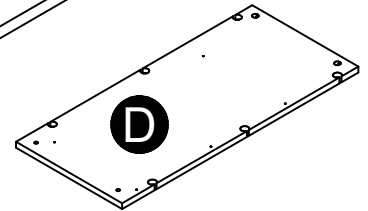

Partition  
33663339040

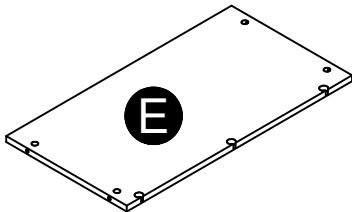

Left Bottom  
33663339050

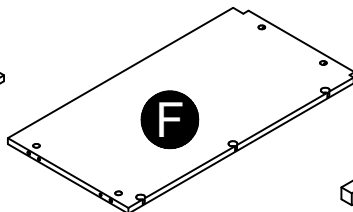

Right Bottom  
33663339060

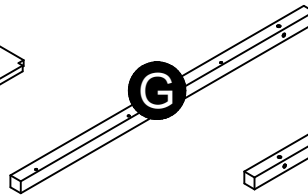

Left Front Leg  
33663339070

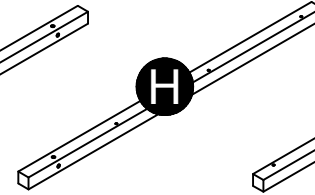

Right Front Leg  
33663339080

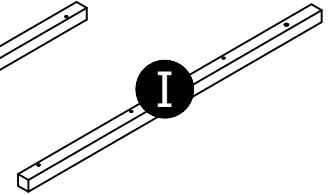

Left Rear Leg  
33663339090

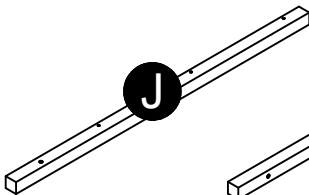

Right Rear Leg  
33663339100

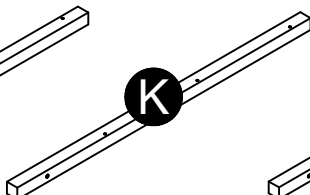

Center Front Leg  
33663339110

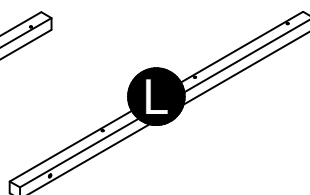

Center Rear Leg  
33663339120

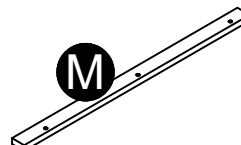

Shelf Rail (x2)  
33663339130

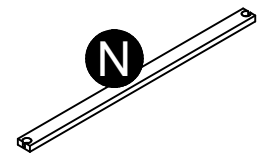

Base Long Rail (x4)  
33663339140

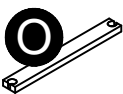

Base Side Rail (x2)  
33663339150

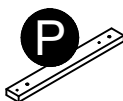

Drawer Rail (x3)  
33663339160

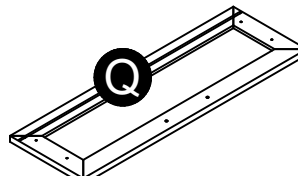

Drawer Front (x6)  
33663339170

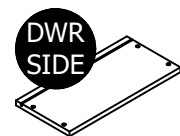

Drawer Side (x12)  
39991167346200C

# Board Identification

Not actual size

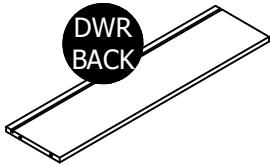

Drawer Back (x6)  
39991167065390B

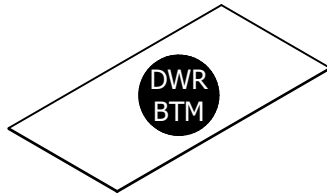

Drawer Bottom (x6)  
39991340066410D

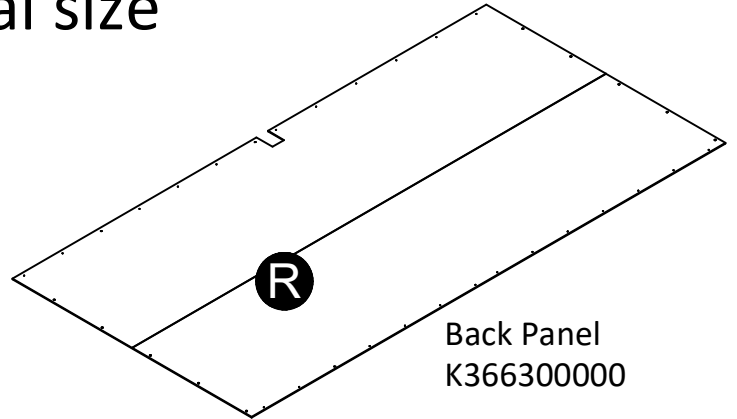

Back Panel  
K366300000

This piece is paperboard construction. It is not made from wood, but is required for the assembly of your unit.

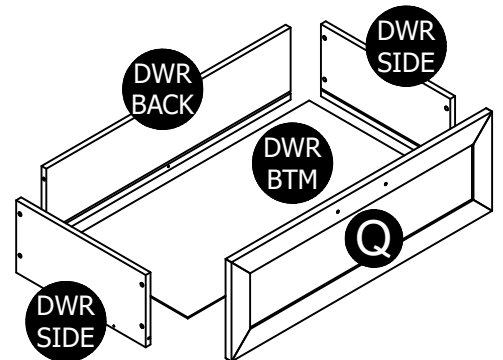
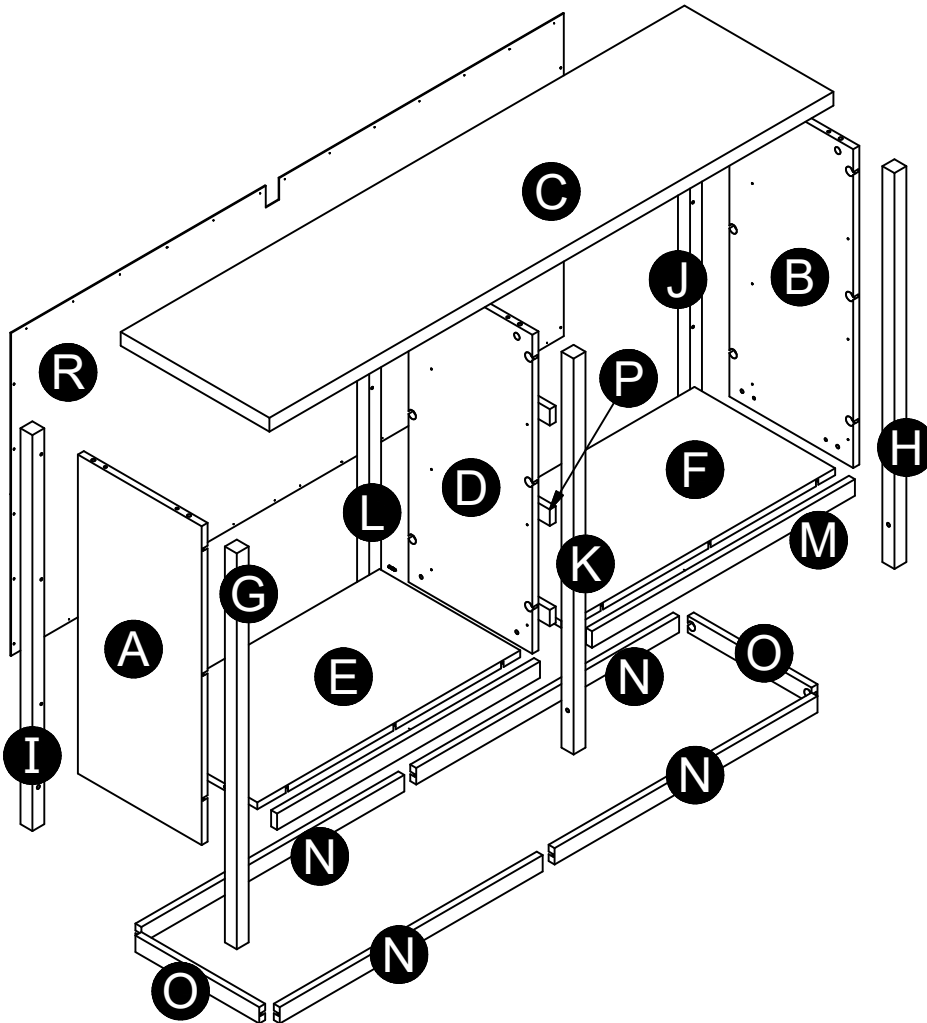

## Part List

### Actual Size

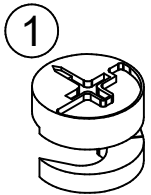

(x14)  
#A22700  
cam lock

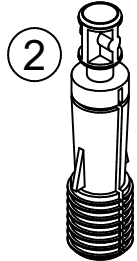

(x14)  
#A22710  
cam bolt

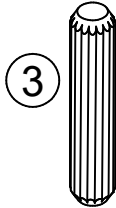

(x10)  
#A21670  
wood dowel

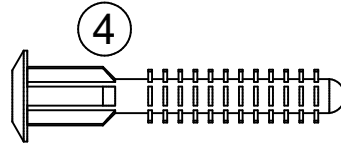

(x24)  
#A21970  
drive fastener



(x18)  
#A22910  
connector bolt

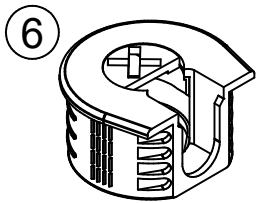

(x18)  
#A22900  
connector



(x48)  
#A11080  
7/16" flat head



(x70)  
#A12120  
7/16" pan head

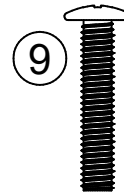

(x12)  
#A17400  
3/4" bolt

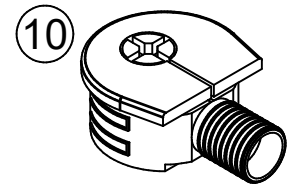

(x18)  
#A22770  
quickloc

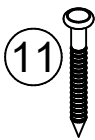

(x28)  
#A21110  
nail

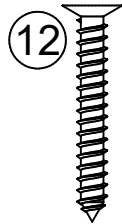

(x6)  
#A12950  
1-1/4" flat head

### Not Actual Size

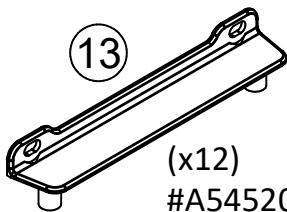

(x12)  
#A54520  
drawer bracket

(x1)  
#A84050  
safety bracket kit

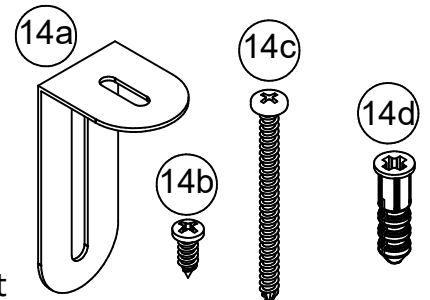

# Part List

Not Actual Size

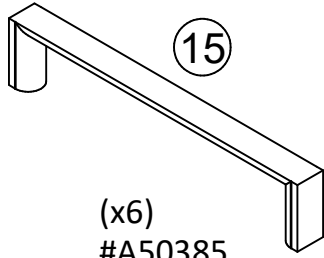

(x6)  
#A50385  
handle

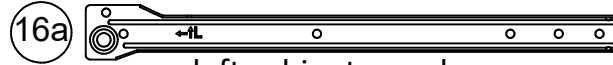

left cabinet member



right cabinet member

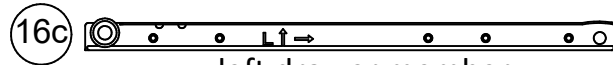

left drawer member

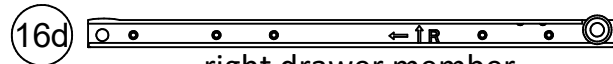

right drawer member

(x6)  
**16** #A56770  
drawer slide kit

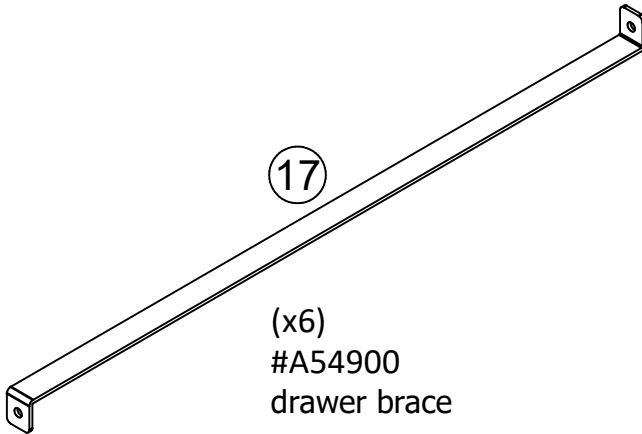

(x6)  
#A54900  
drawer brace



## STEP 1

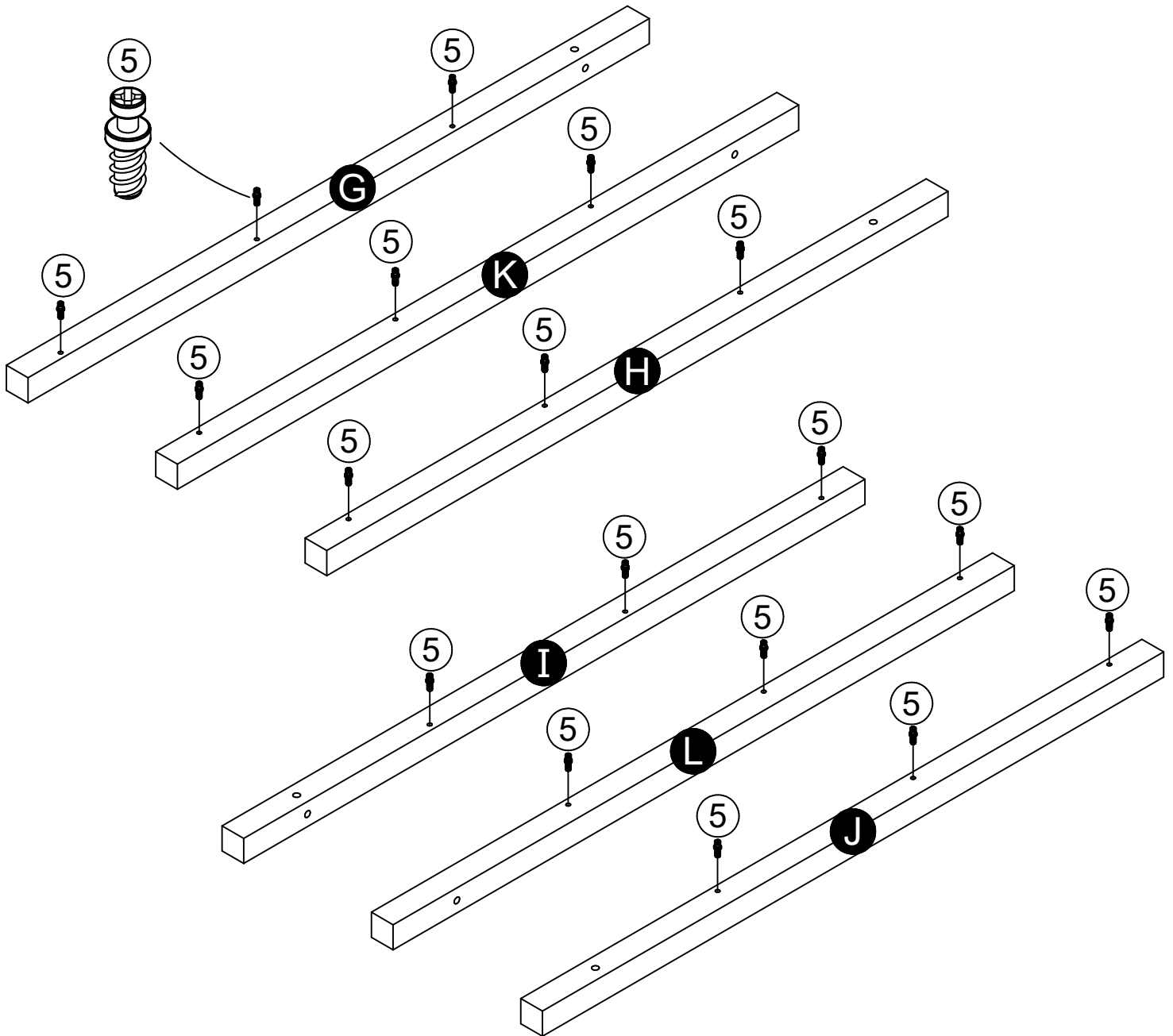
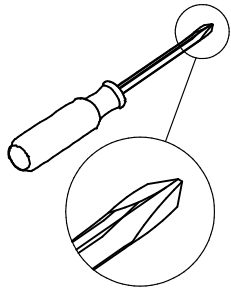

## STEP 2

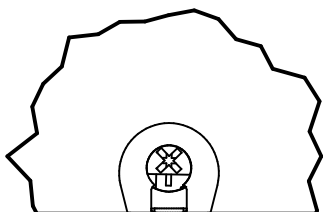
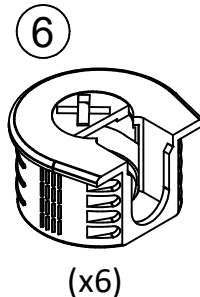
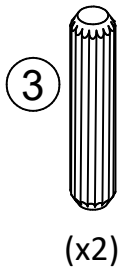
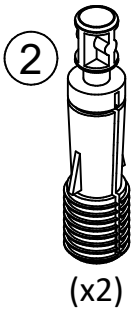
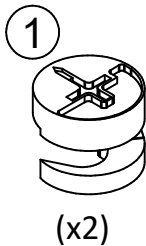
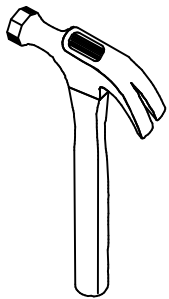

You will need to tap the connector (6) with a hammer to fully insert. Be sure the connector is positioned as shown before tapping into hole.

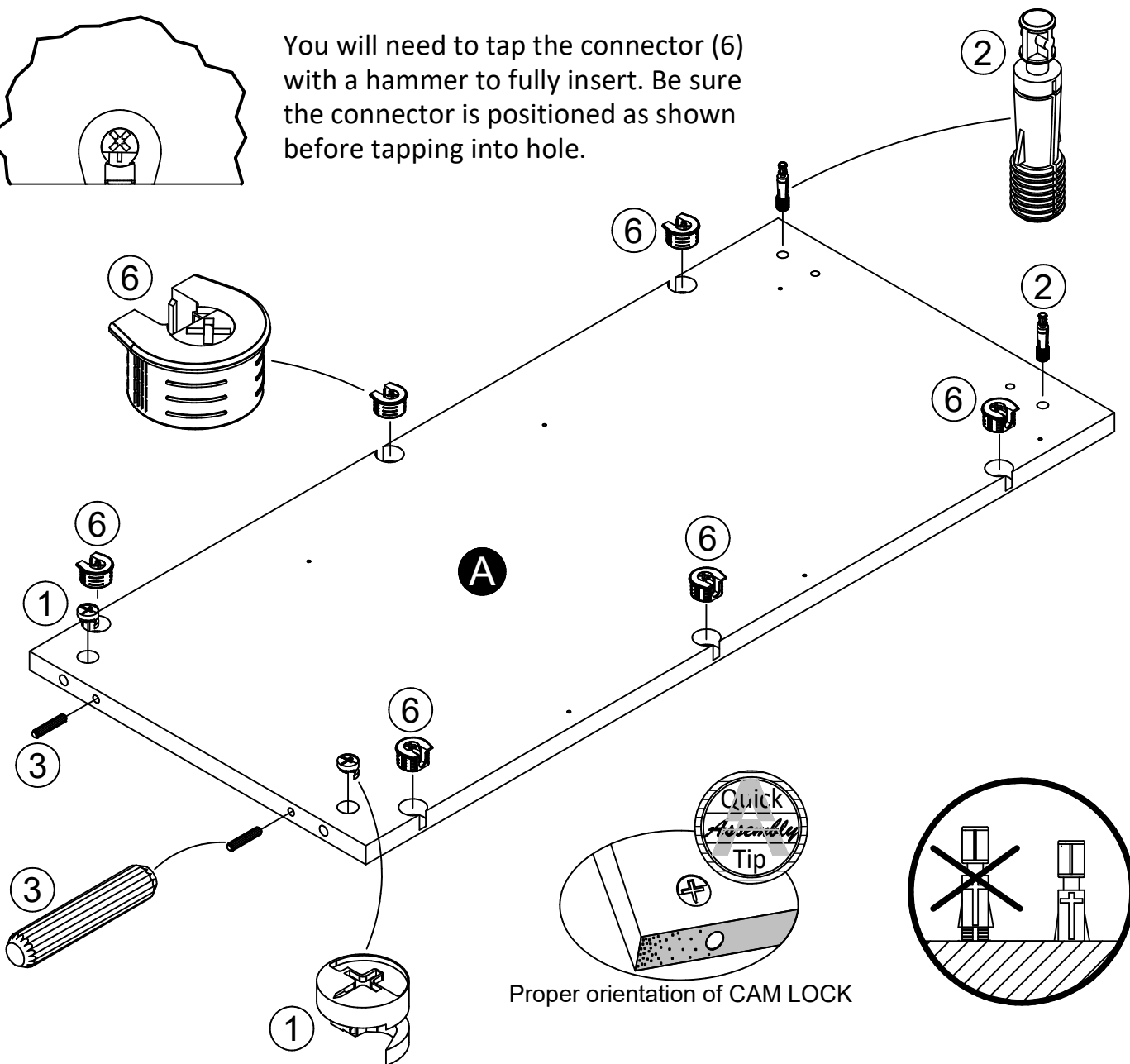

## STEP 3

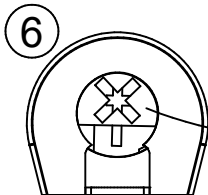
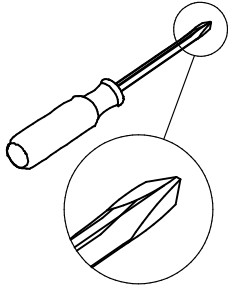

Turn screw clockwise to lock parts in place.

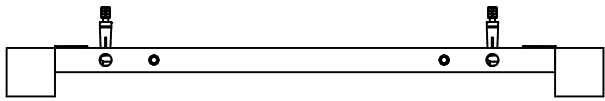
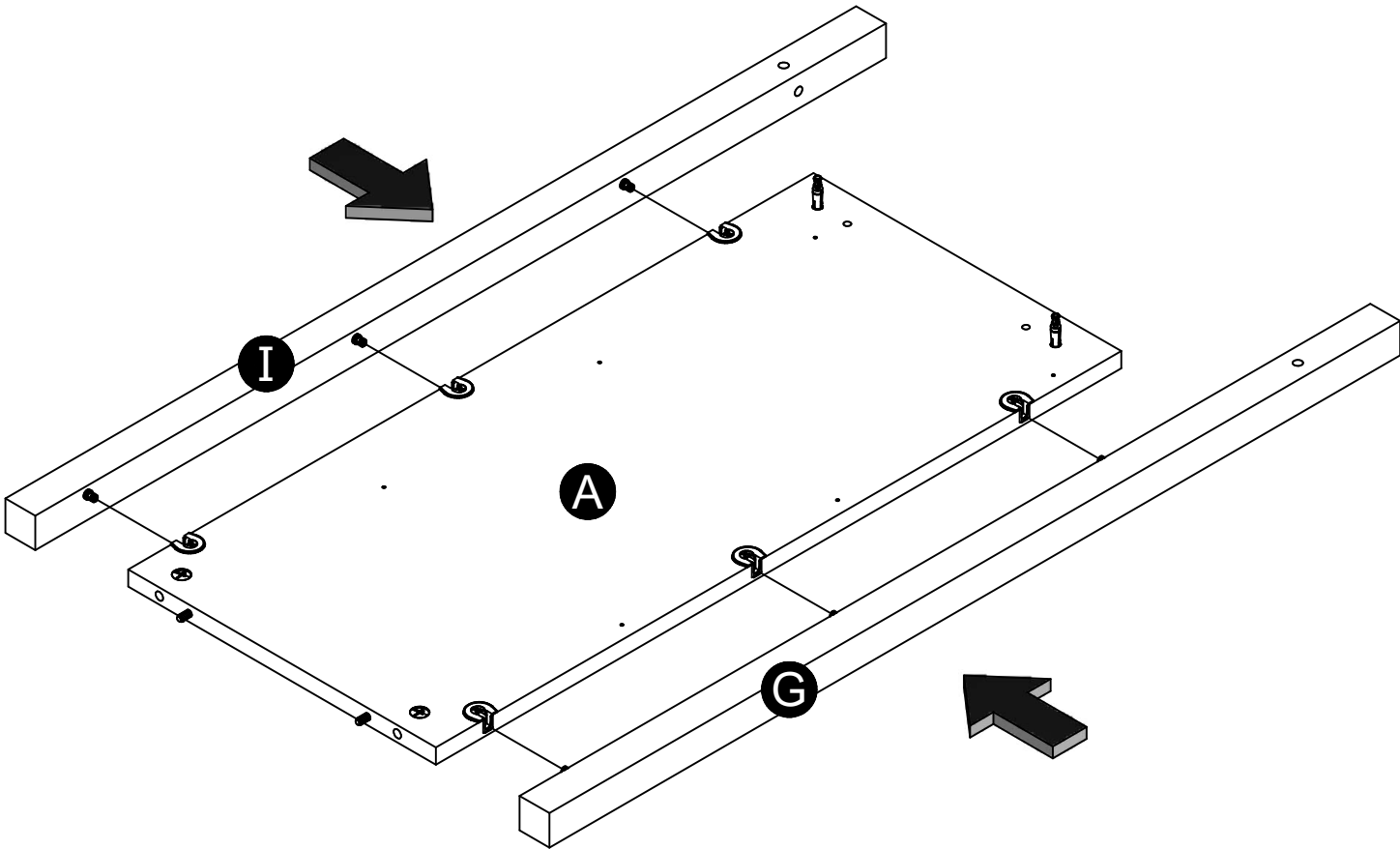

end view

# STEP 4

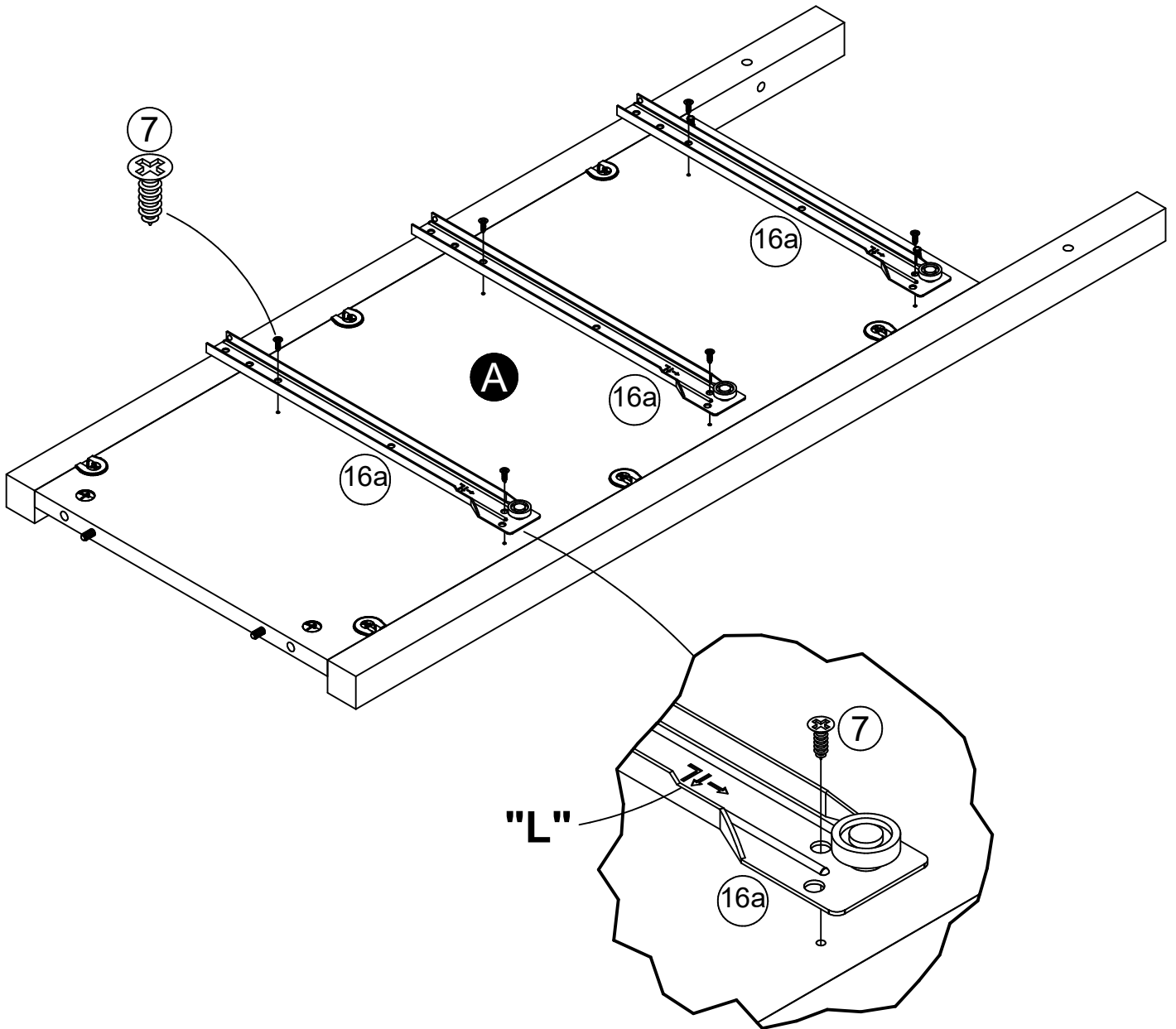
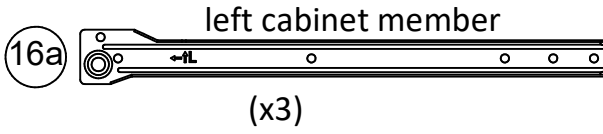
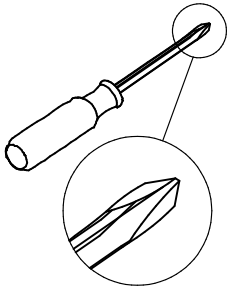

# STEP 5

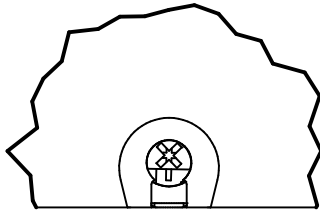
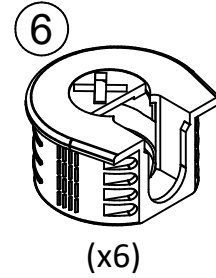
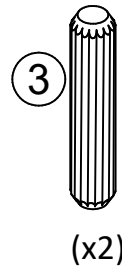
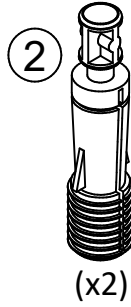
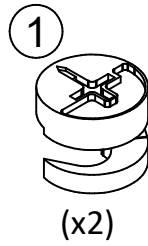
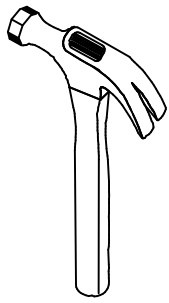

You will need to tap the connector (6) with a hammer to fully insert. Be sure the connector is positioned as shown before tapping into hole.

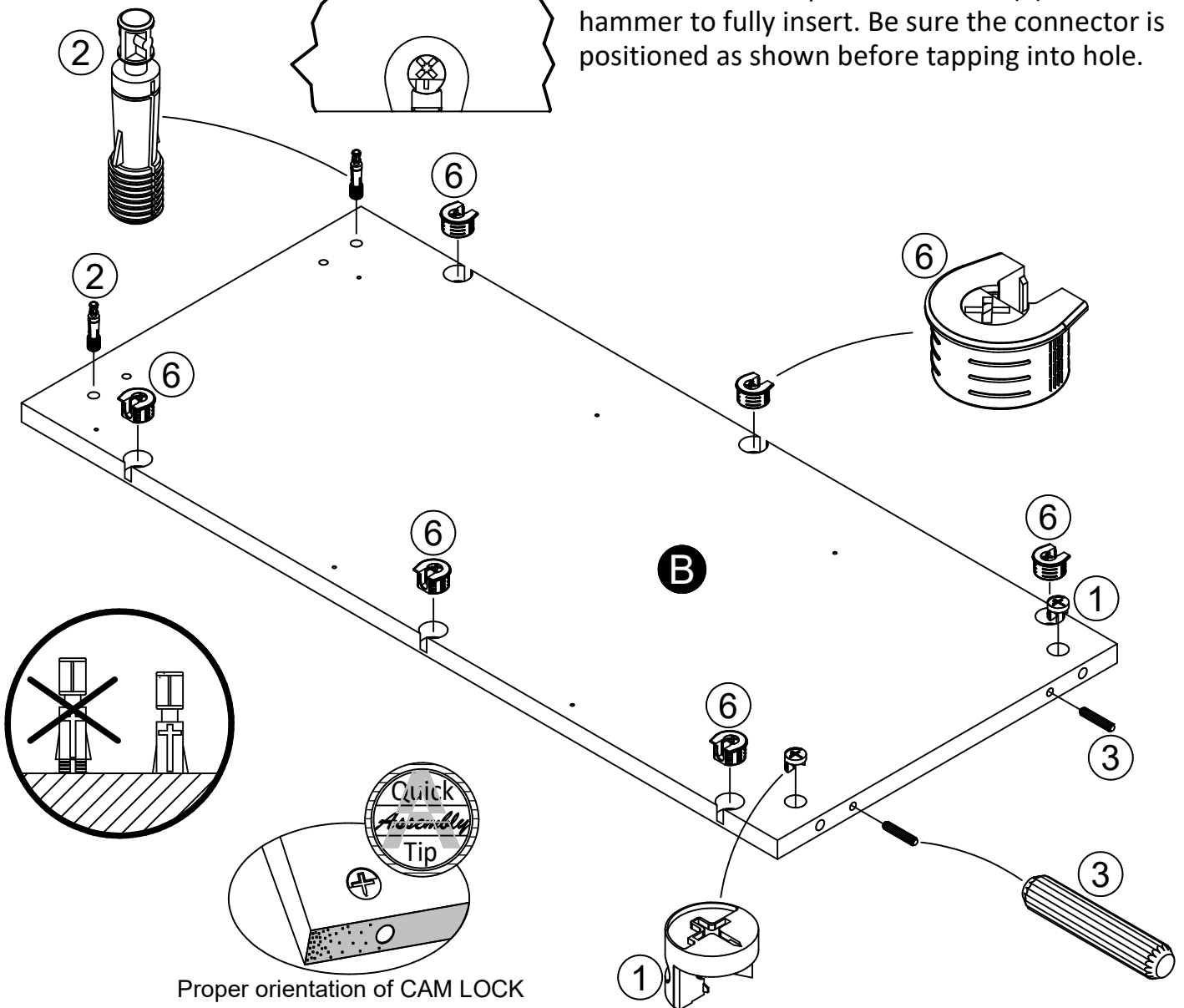

# STEP 6

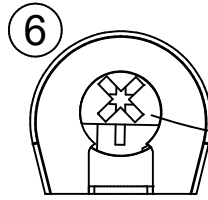
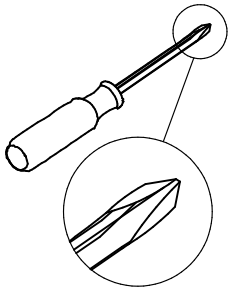

Turn screw clockwise to lock parts in place.

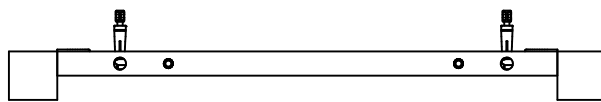
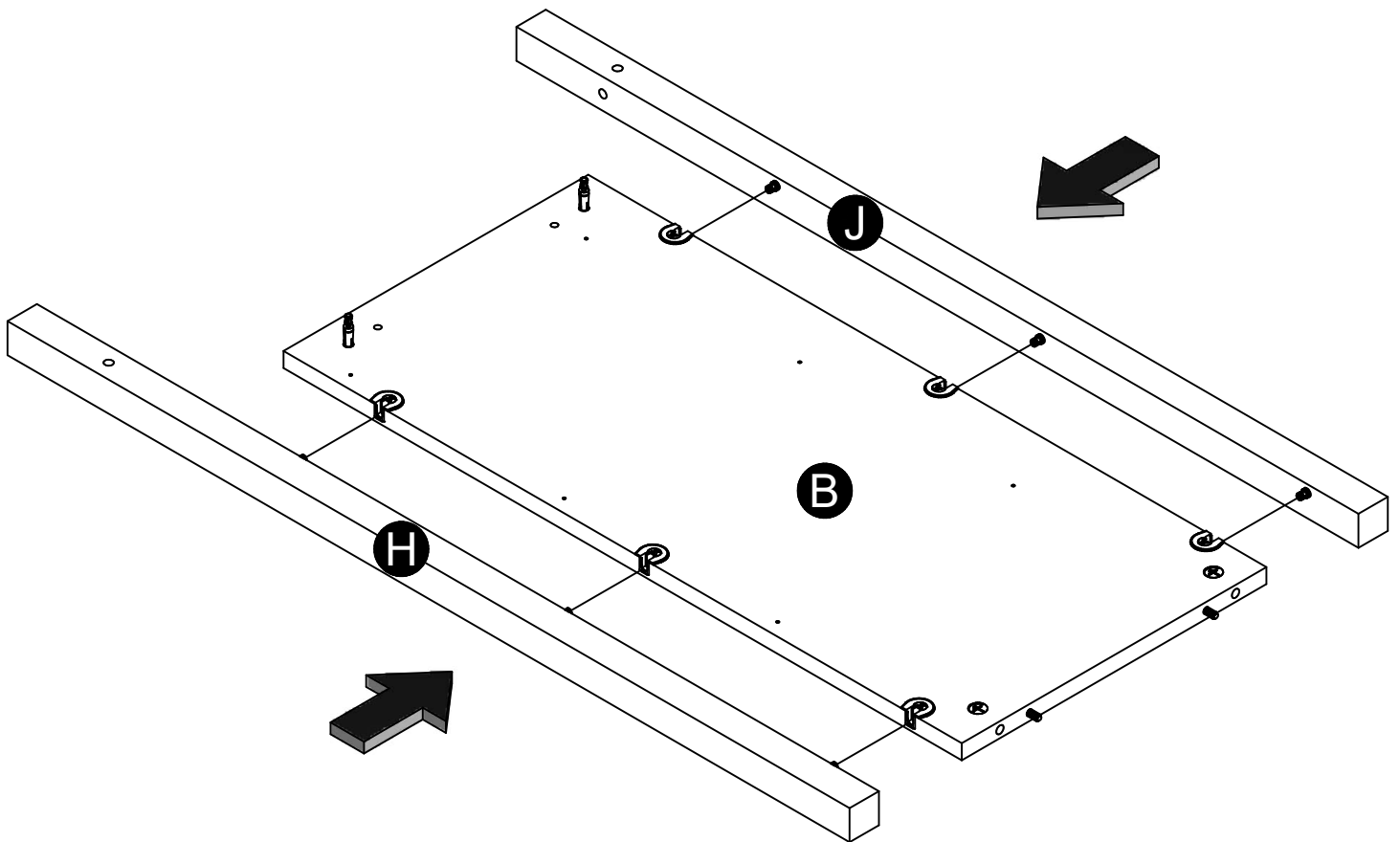

end view

# STEP 7

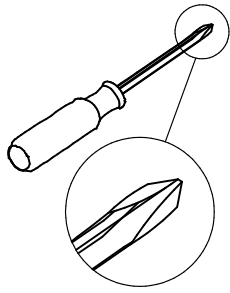

16b

right cabinet member



(x3)

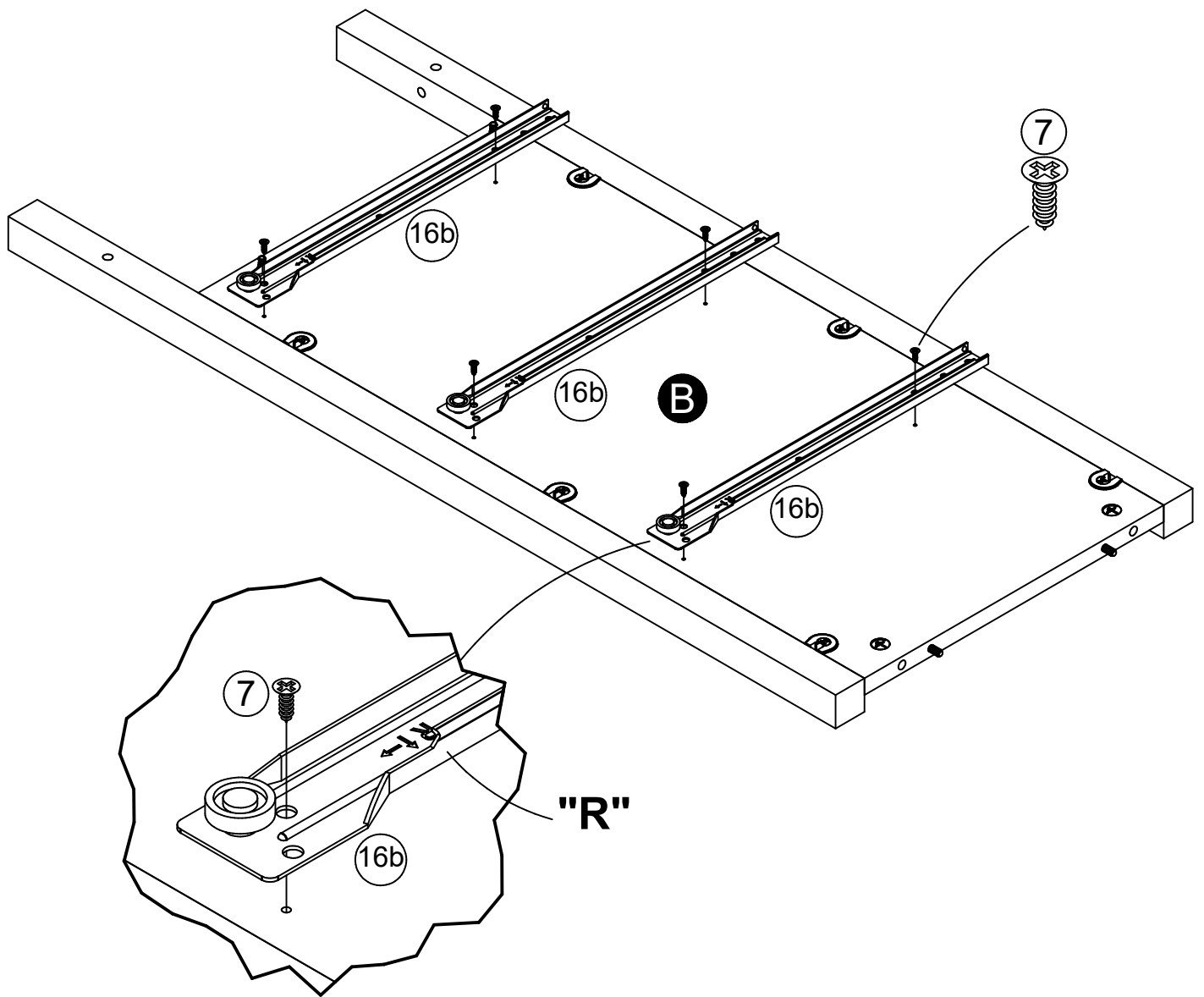

# STEP 8

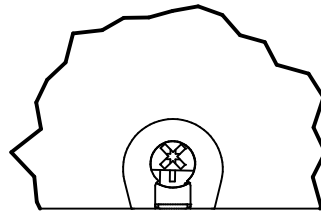
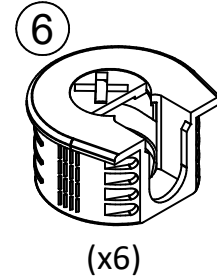
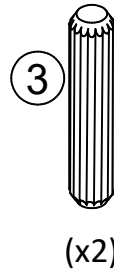
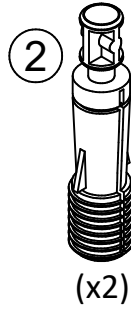
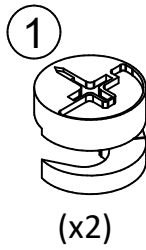
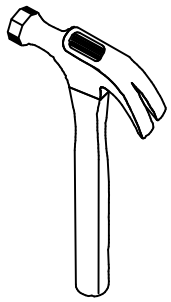

You will need to tap the connector (6) with a hammer to fully insert. Be sure the connector is positioned as shown before tapping into hole.

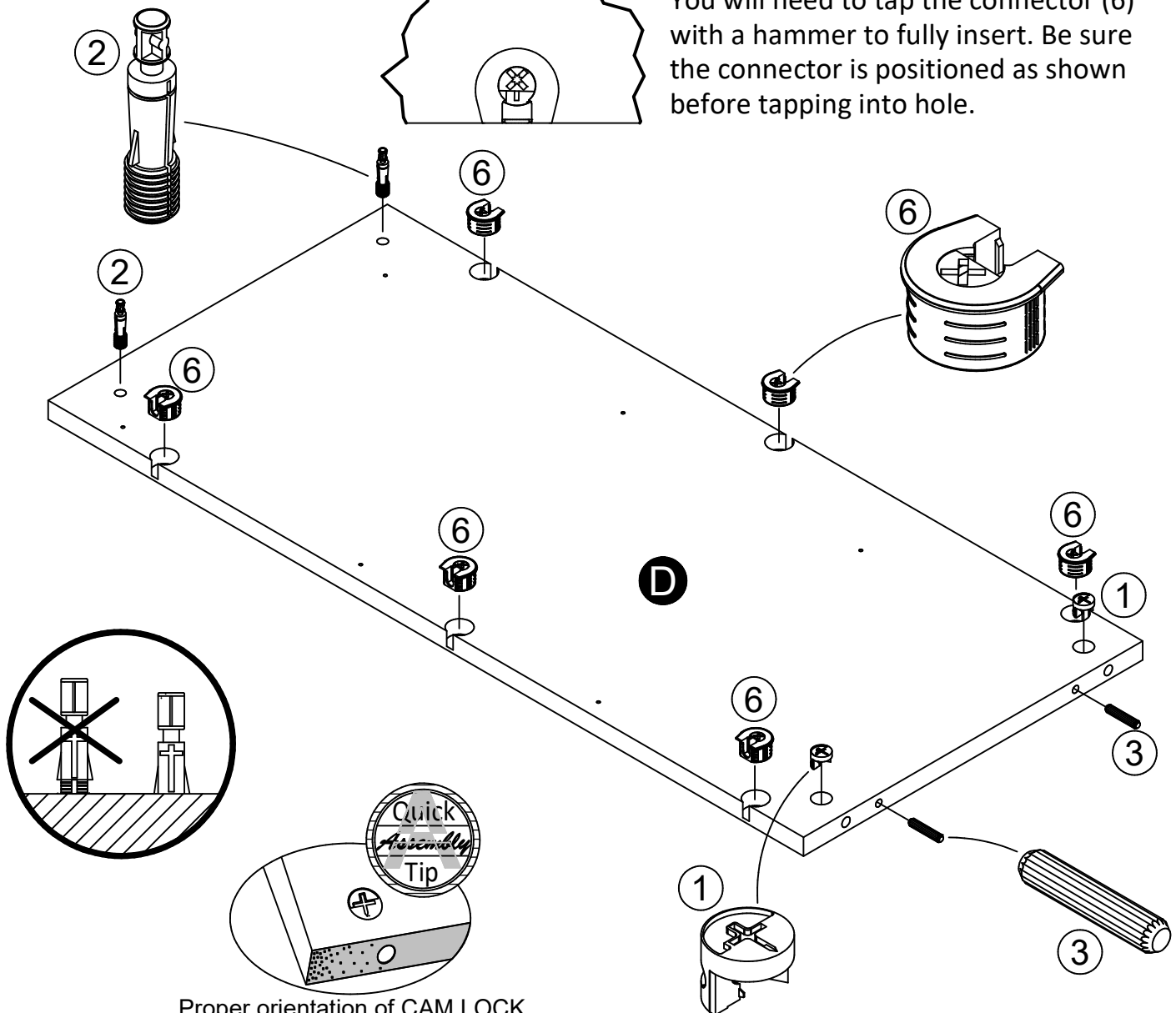

Proper orientation of CAM LOCK



## STEP 9

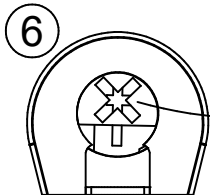
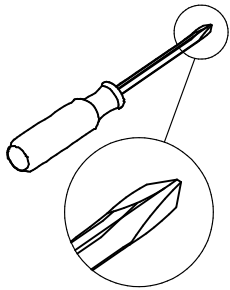

Turn screw clockwise to lock parts in place.

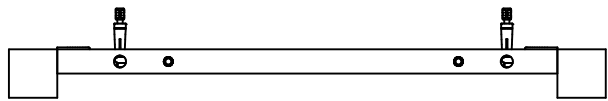
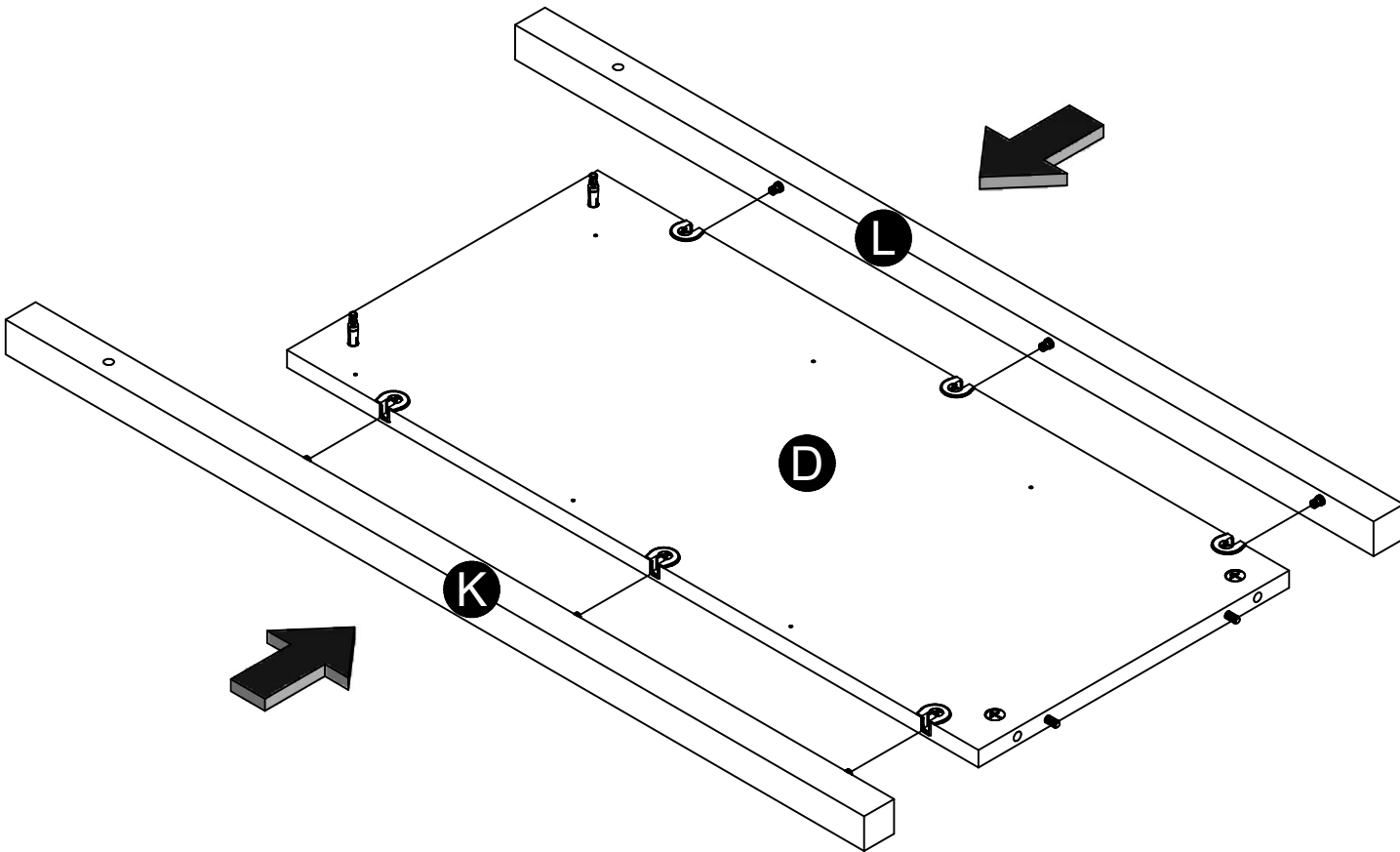

end view

# STEP 10

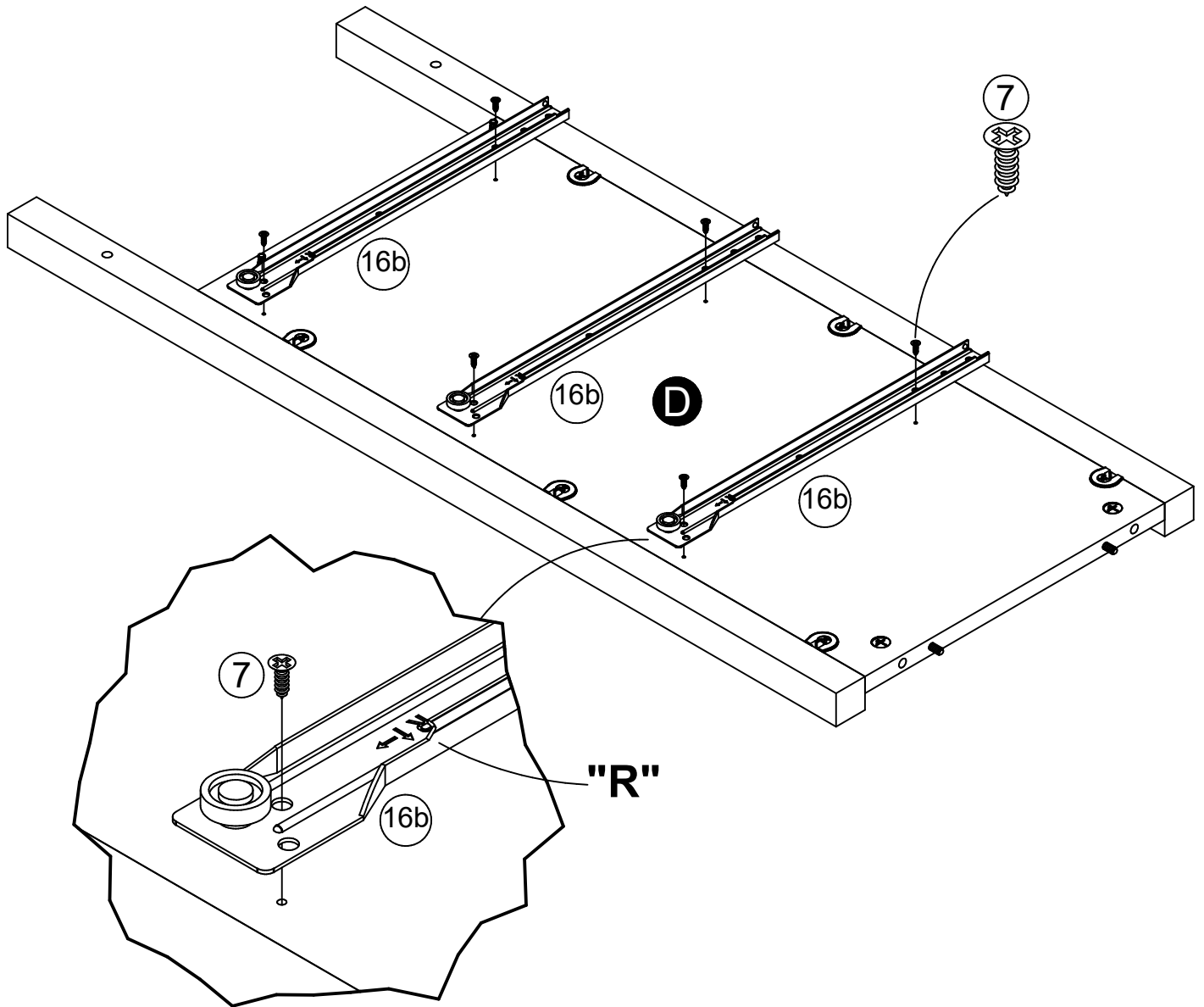
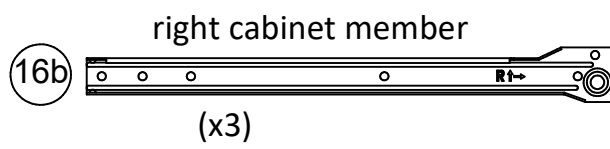
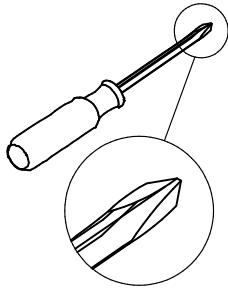

## STEP 11

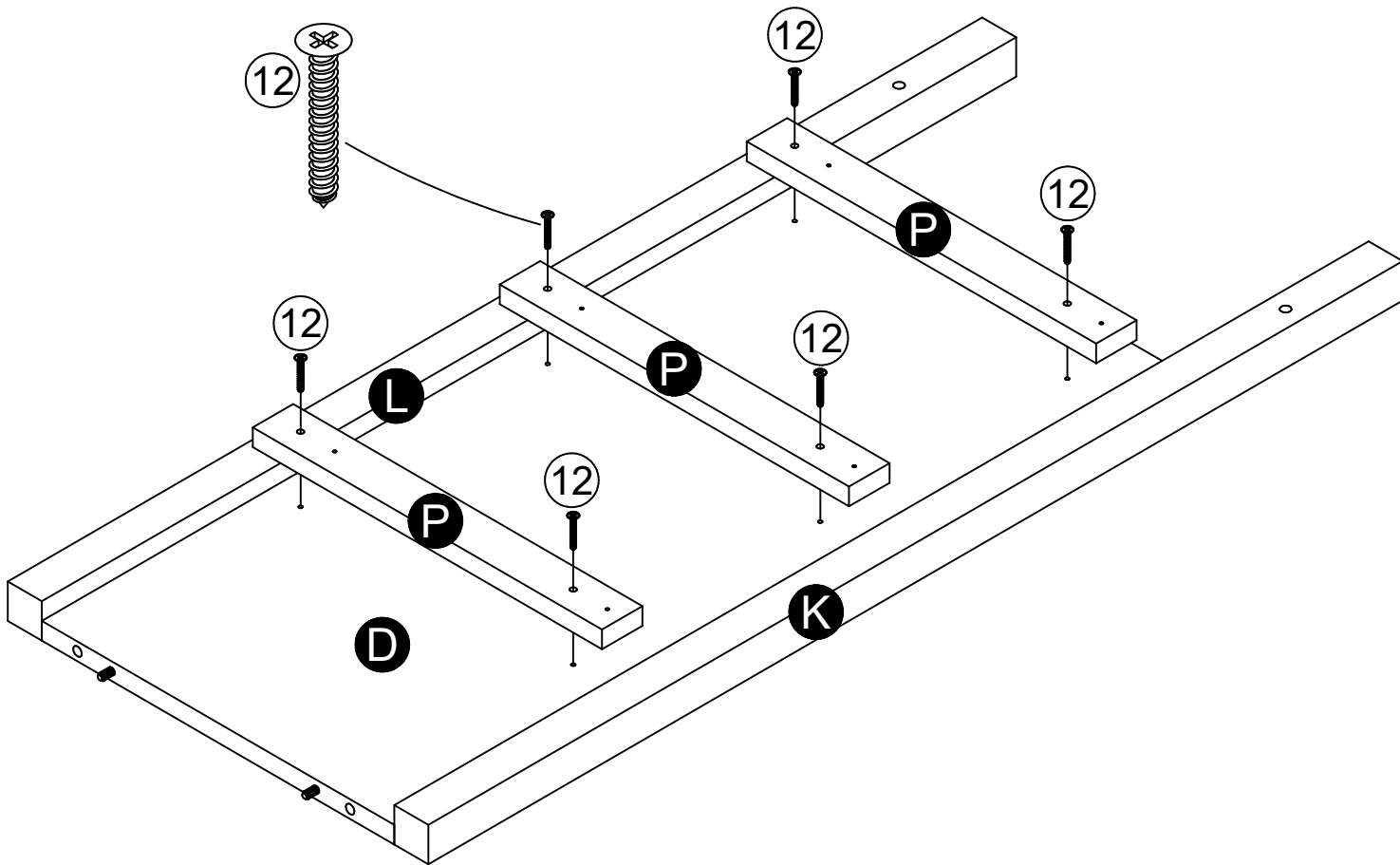
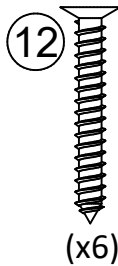
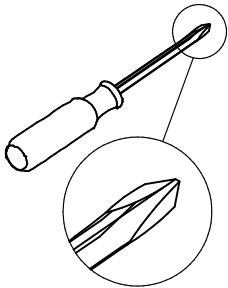

# STEP 12

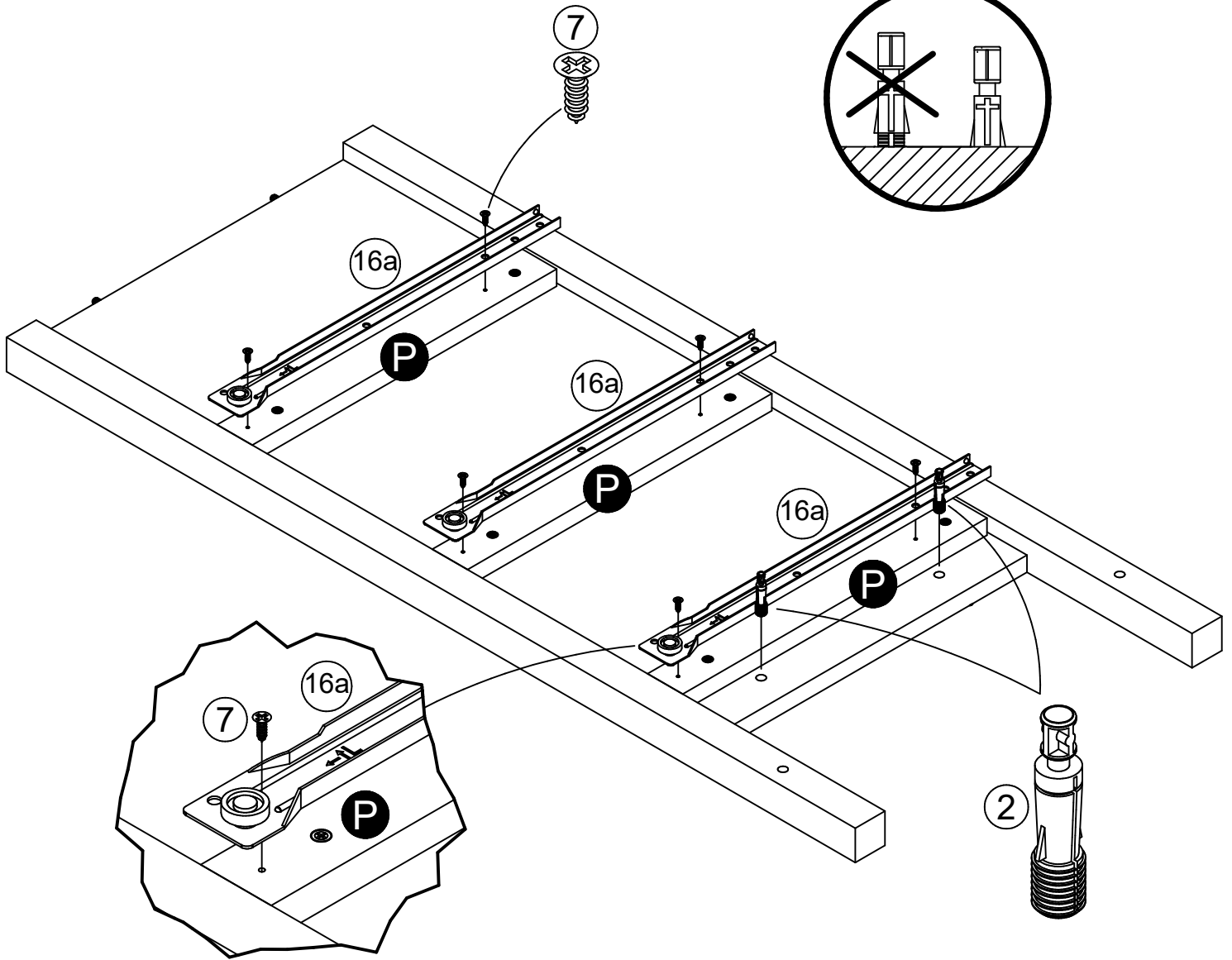
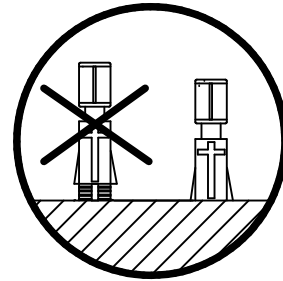
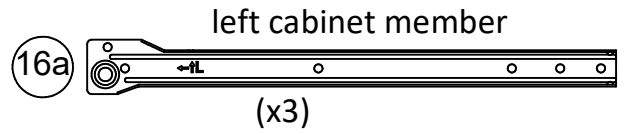
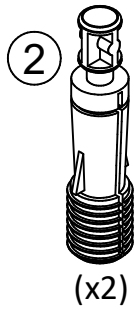
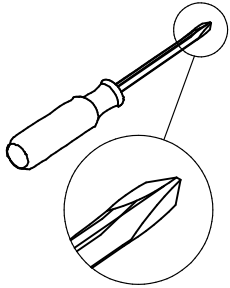

## STEP 13

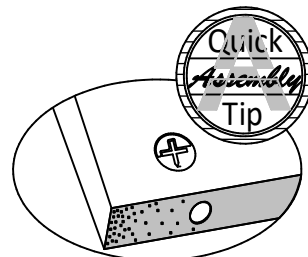
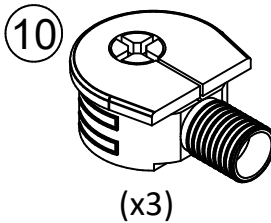
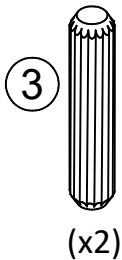
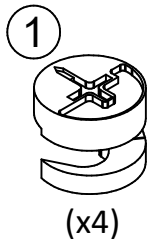

Proper orientation of CAM LOCK

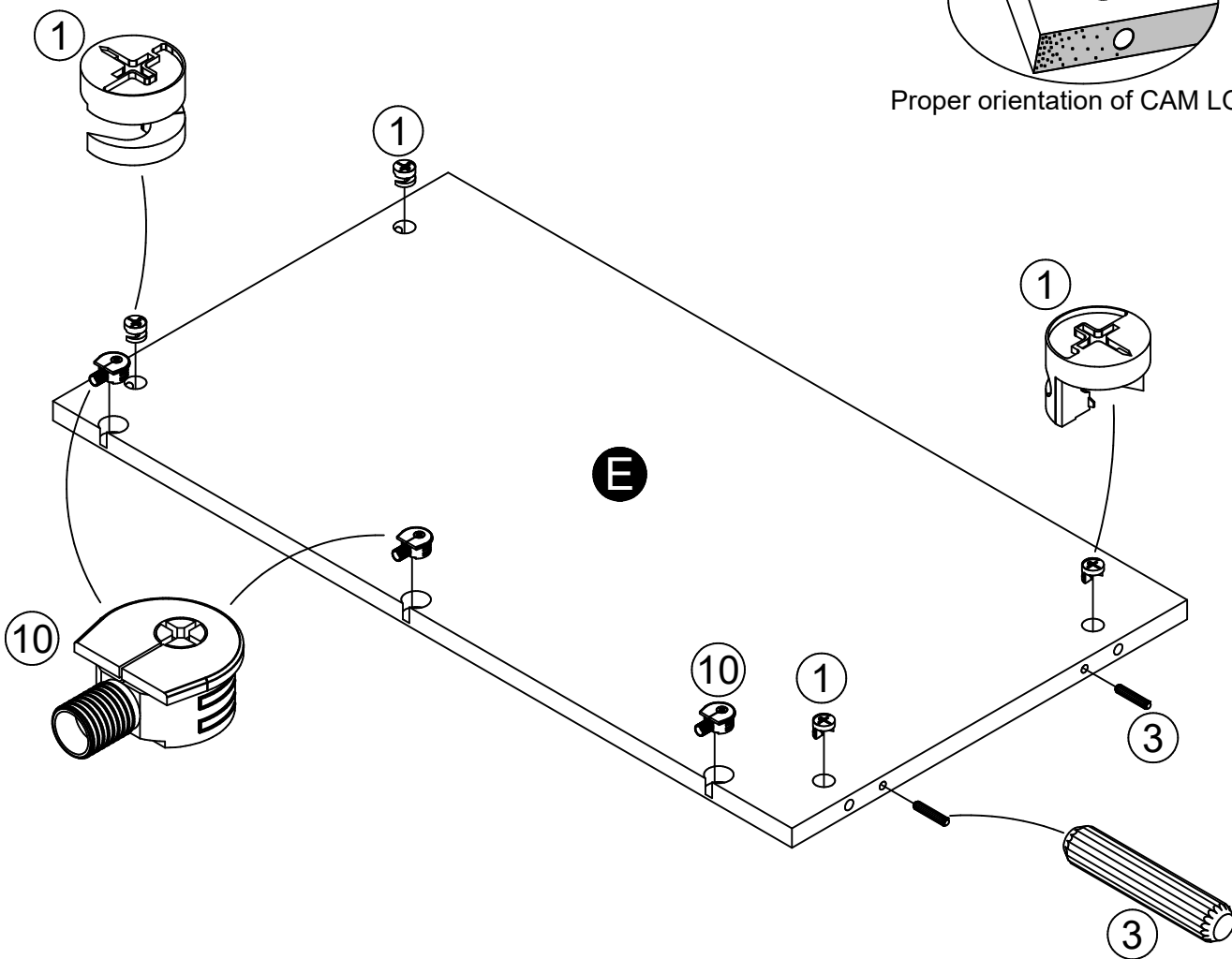

# STEP 14

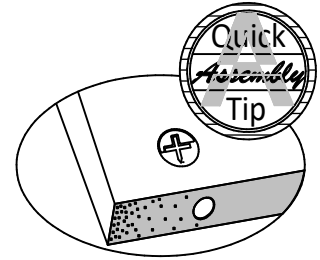
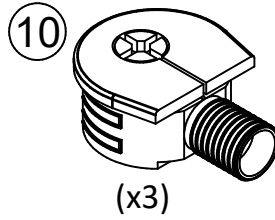
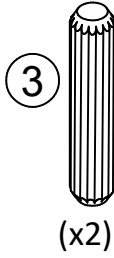
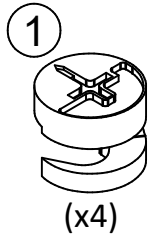

Proper orientation of CAM LOCK

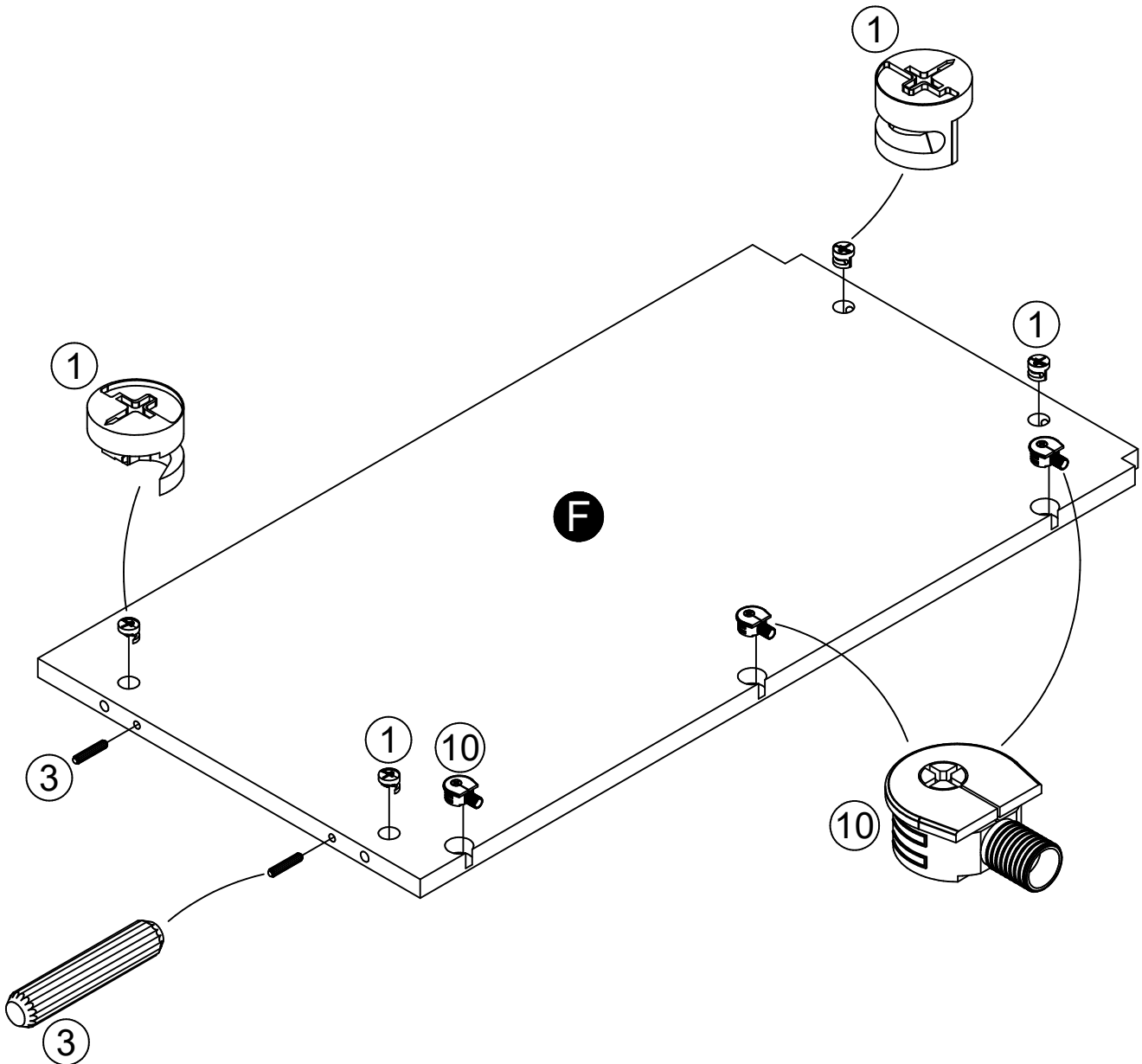

## STEP 15

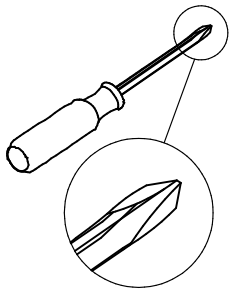

Align the holes in the Shelf Rail (M) with the quicklocs (10) and press down. Turn screw in quickloc clockwise to lock parts in place.

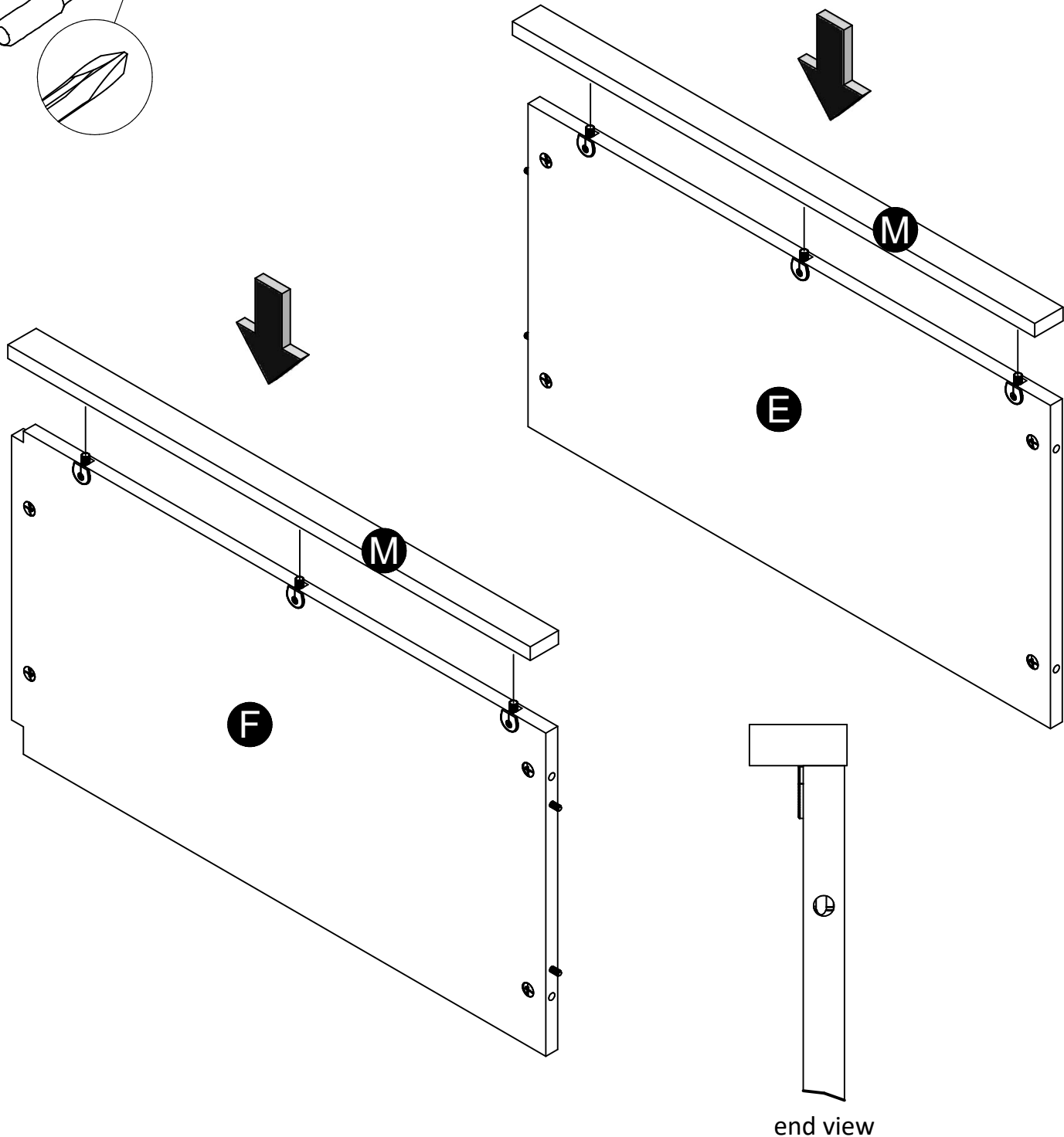

# STEP 16

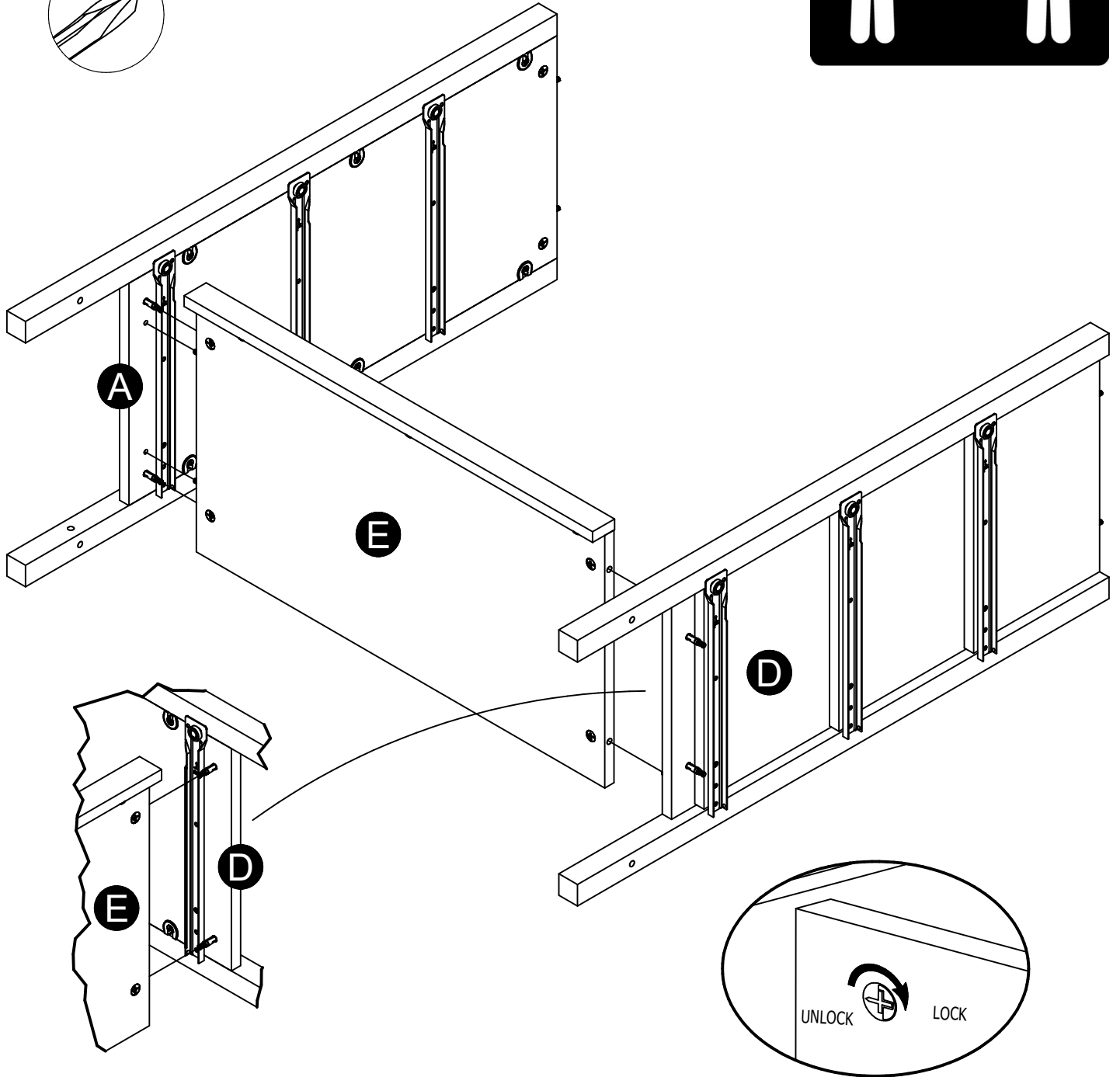
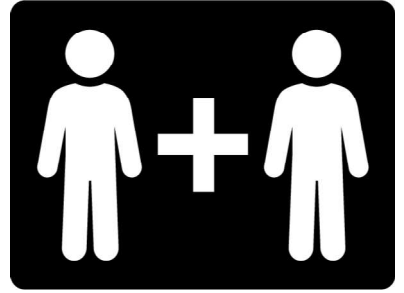
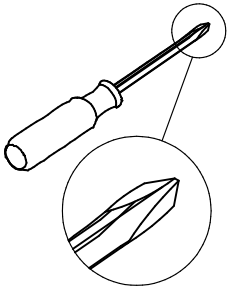



# STEP 17

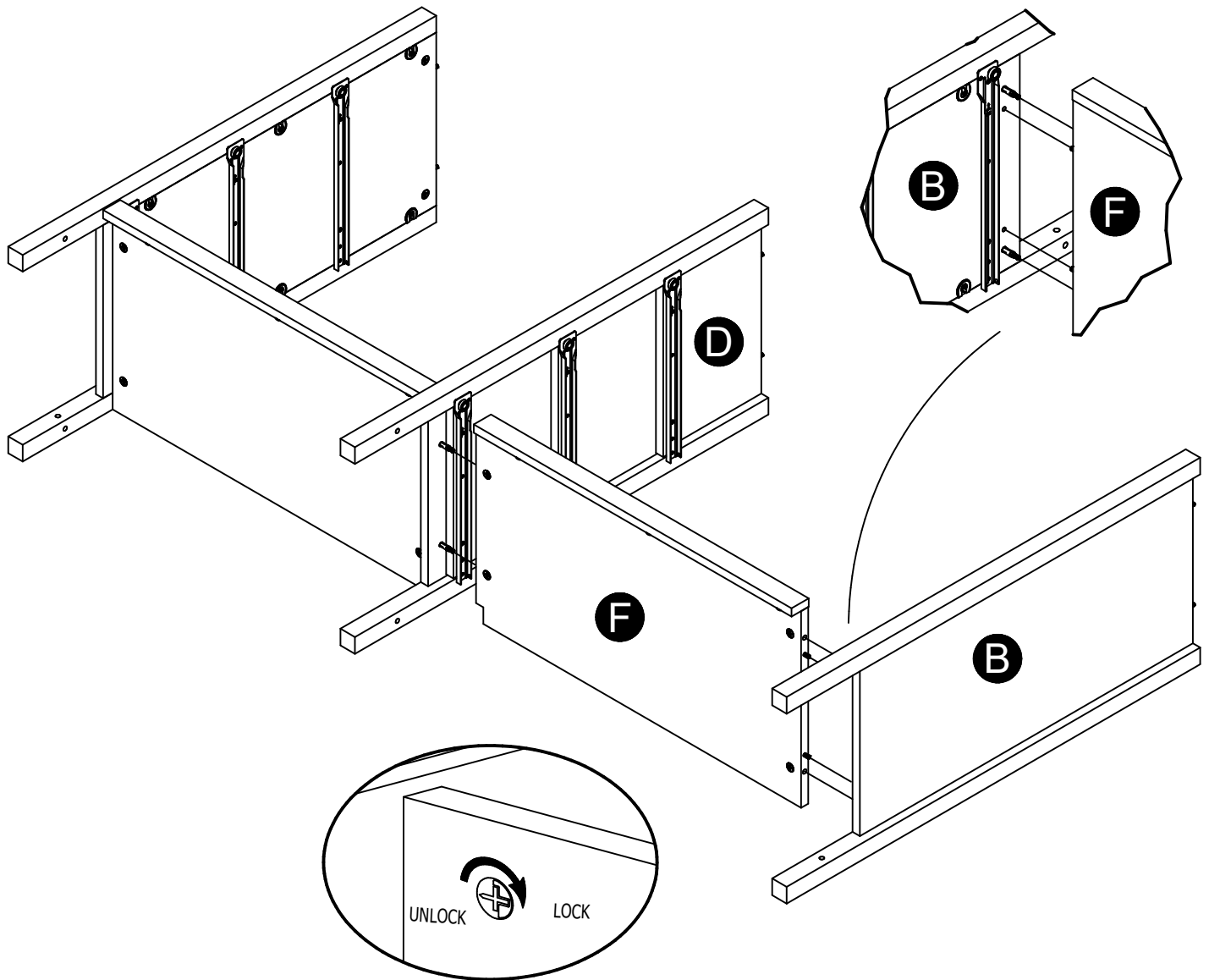
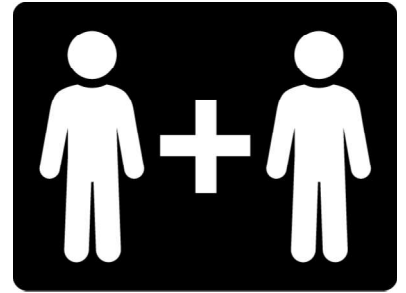
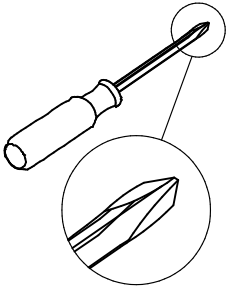

# STEP 18

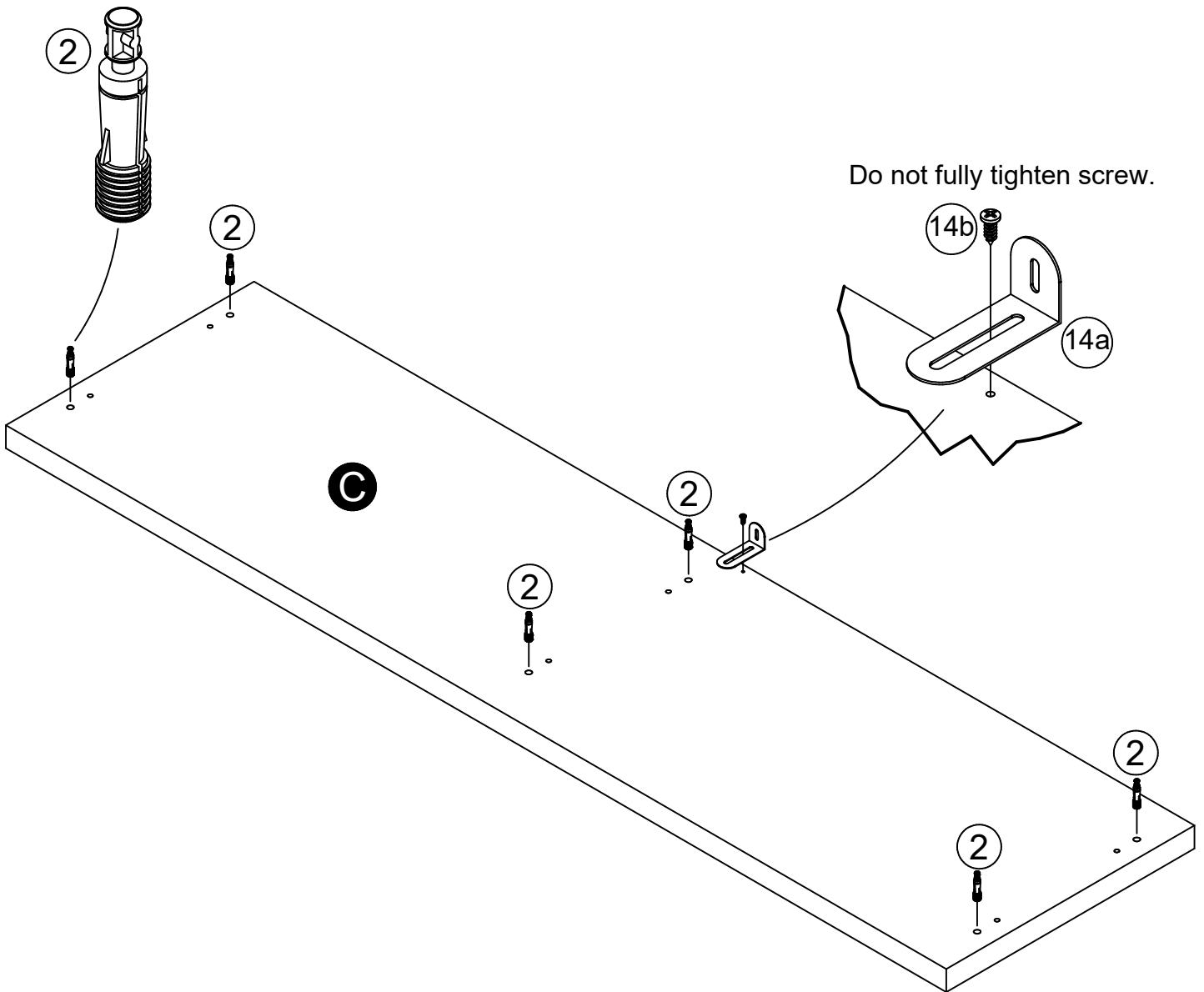
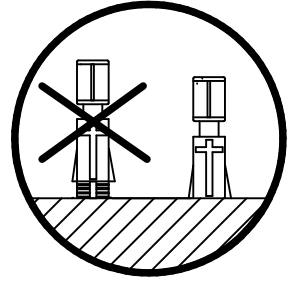
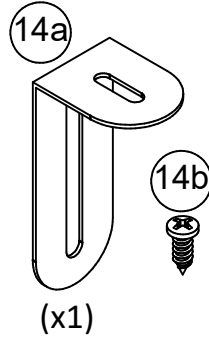
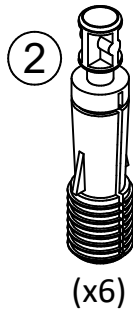
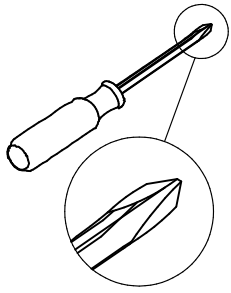

## STEP 19

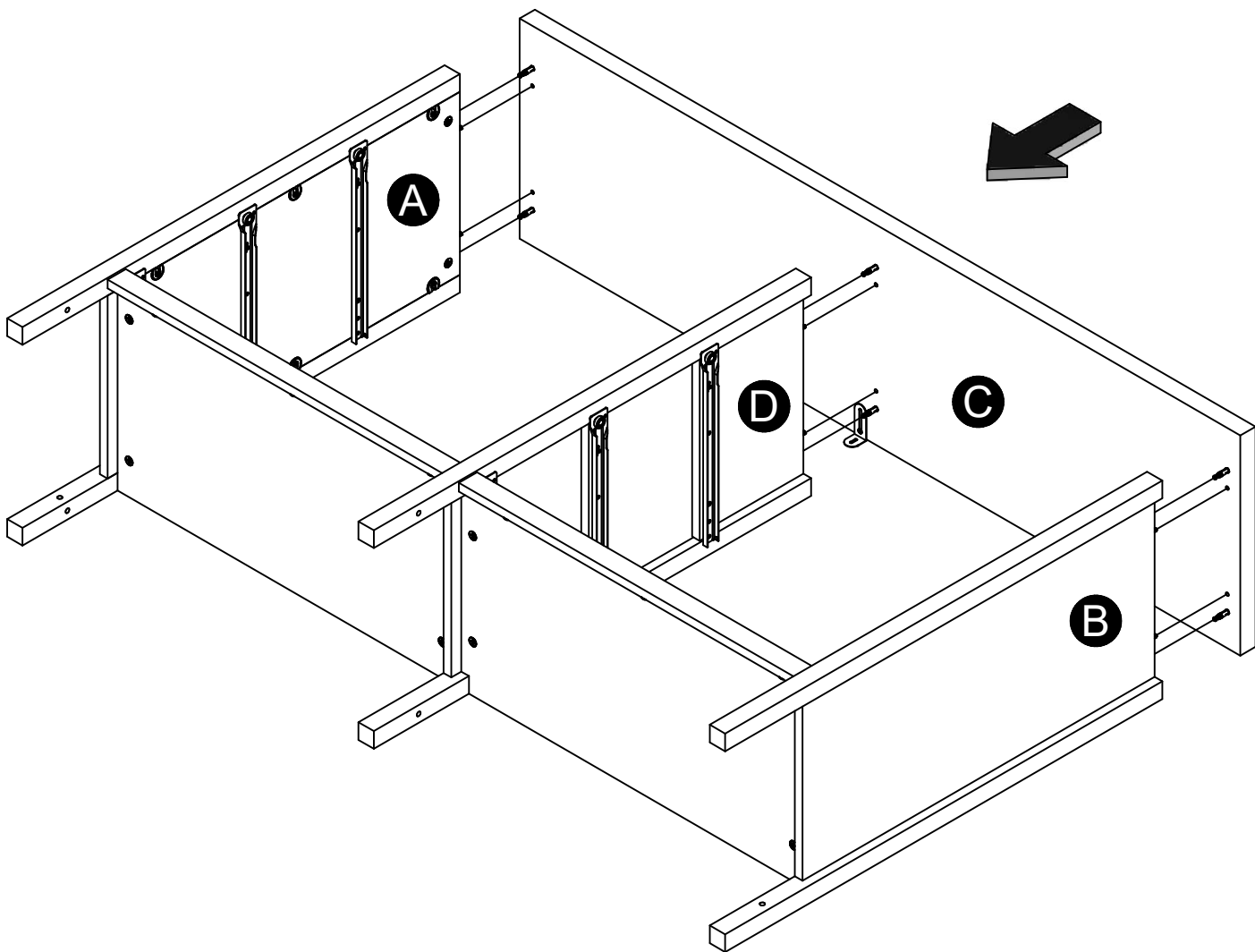
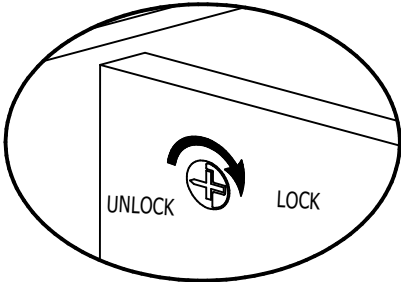
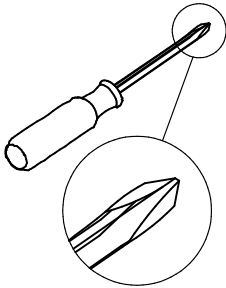

# STEP 20

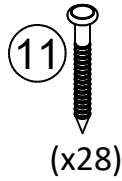
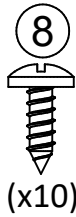
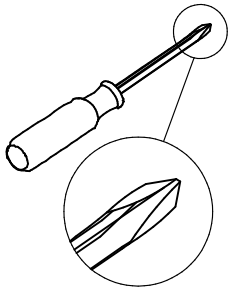

**IMPORTANT! THE BACK PANEL IS A STRUCTURAL PART OF THIS UNIT AND MUST BE INSTALLED PROPERLY.**

Attached the back panel as shown nailing straight into the raw edges across the top and bottom and using screws (8) to screw into back of legs I and J.

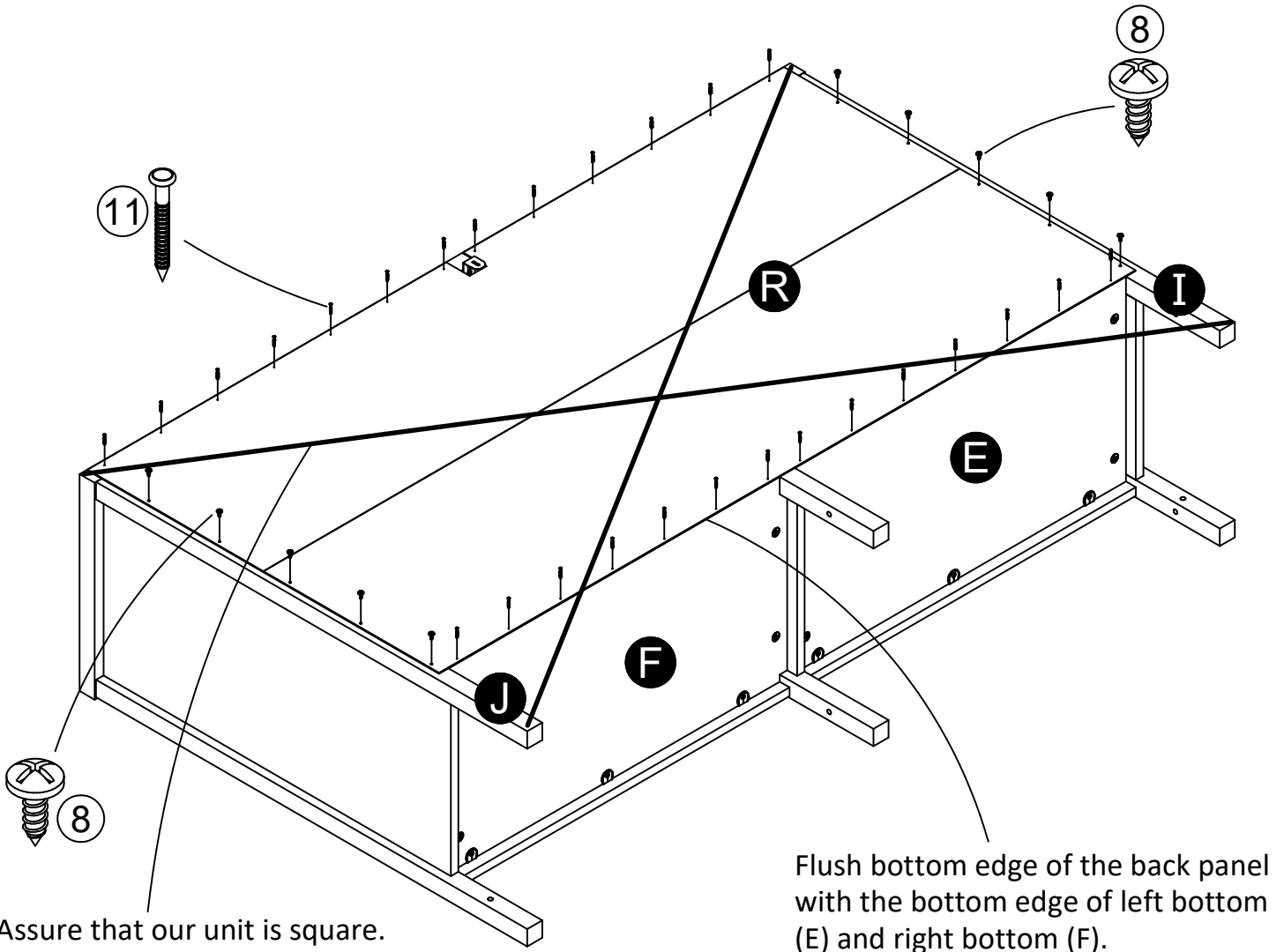

Assure that our unit is square. Distance from corner to corner must be equal as shown.

Flush bottom edge of the back panel with the bottom edge of left bottom (E) and right bottom (F).

# STEP 21

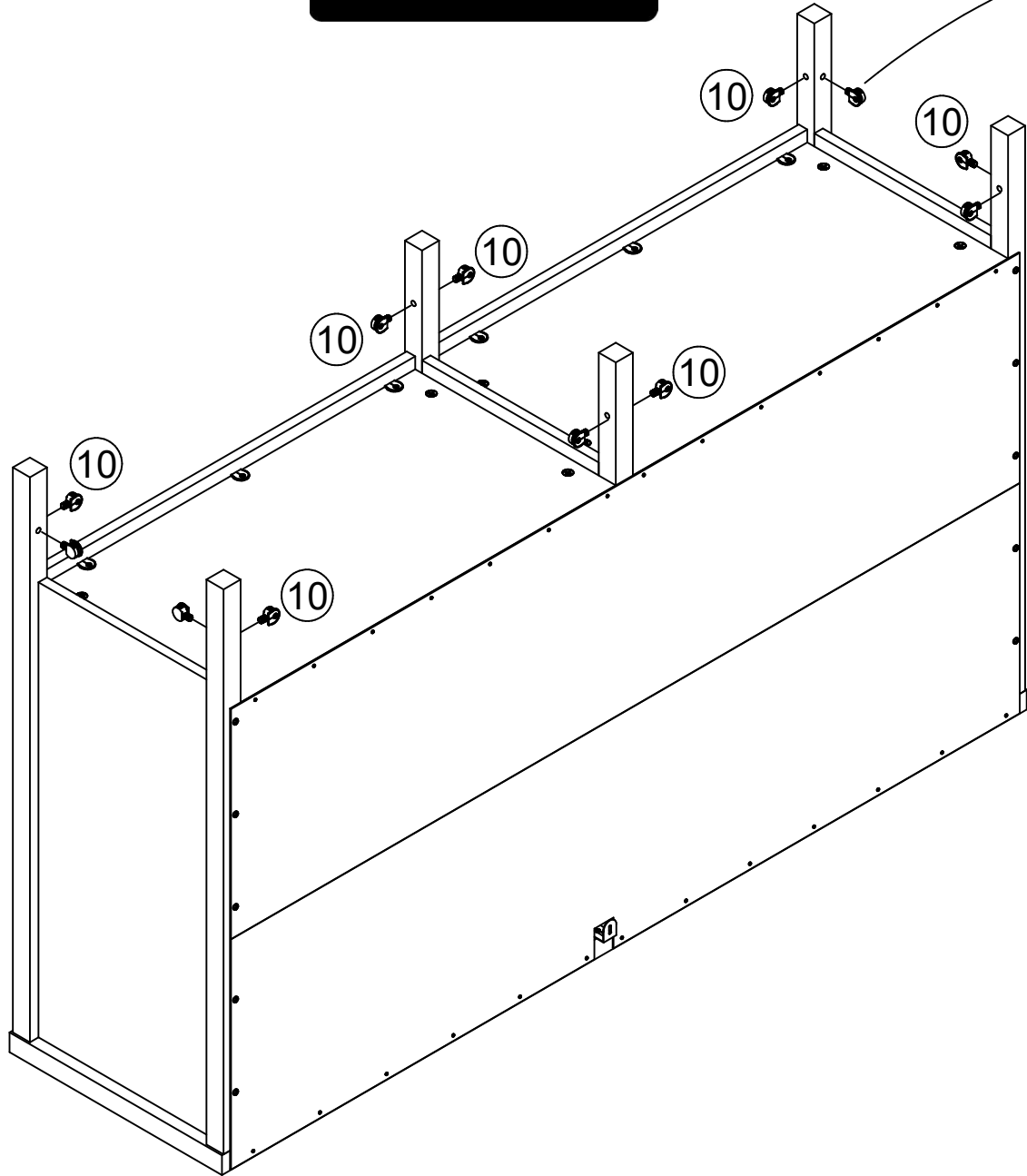
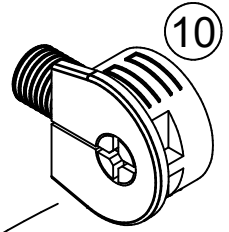
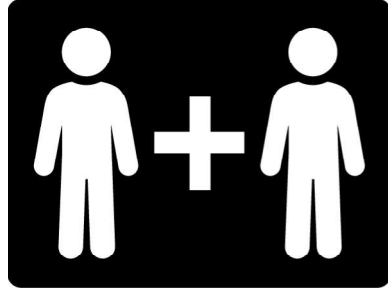
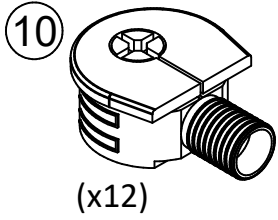

## STEP 22

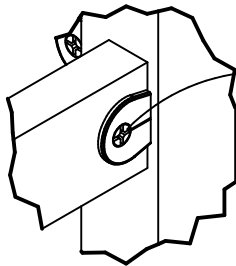
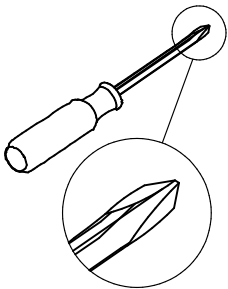

Turn screw clockwise to lock parts together.

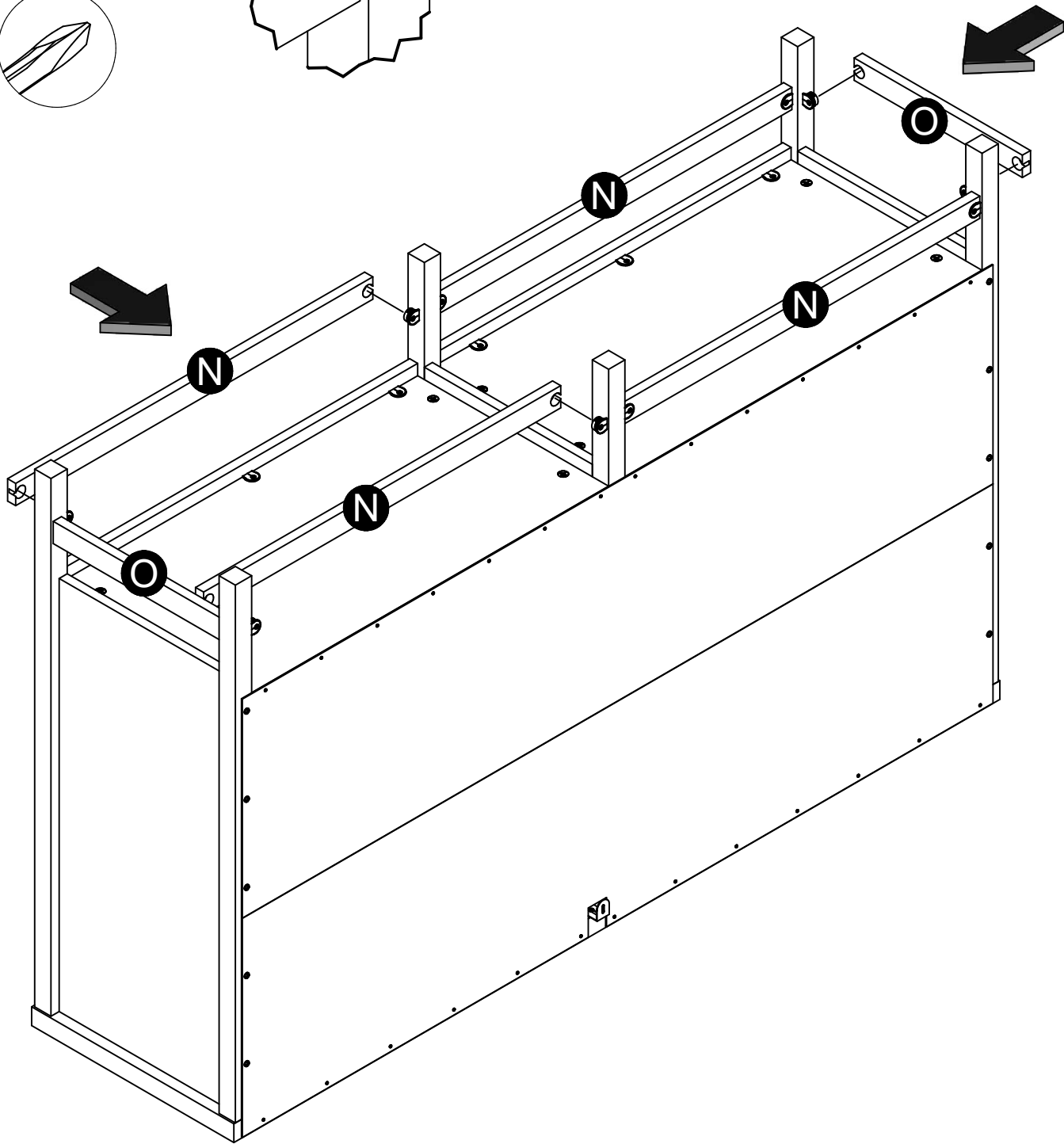

## STEP 23

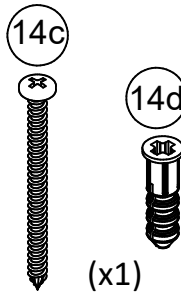
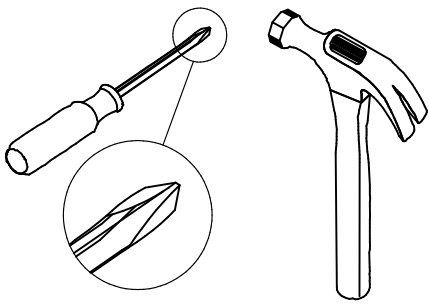

**For Masonry, Concrete, or other wall materials:**  
Consult your local hardware store for appropriate anchors to securely attach the safety bracket.

**IMPORTANT:** THIS UNIT MUST BE SECURE TO THE WALL TO HELP PREVENT TIPOVER. FOLLOW THESE INSTRUCTIONS TO INSTALL THE ANTI-TIPPING SAFETY BRACKET PROVIDED WITH THIS PRODUCT.

### WARNING

**Serious or fatal crushing injuries can occur from furniture tipover.**

**To prevent tipover:**

- \* Install tipover restraint provided
- \* Place heaviest items in the lowest drawers
- \* Unless specifically designed to accommodate, do not set TVs or other heavy objects on the top of this product
- \* Never allow children to climb or hang on drawers, door, or shelves
- \* Never open more than one drawer at a time

**Use of tipover restraints may only reduce, but not eliminate the risk of tipover**

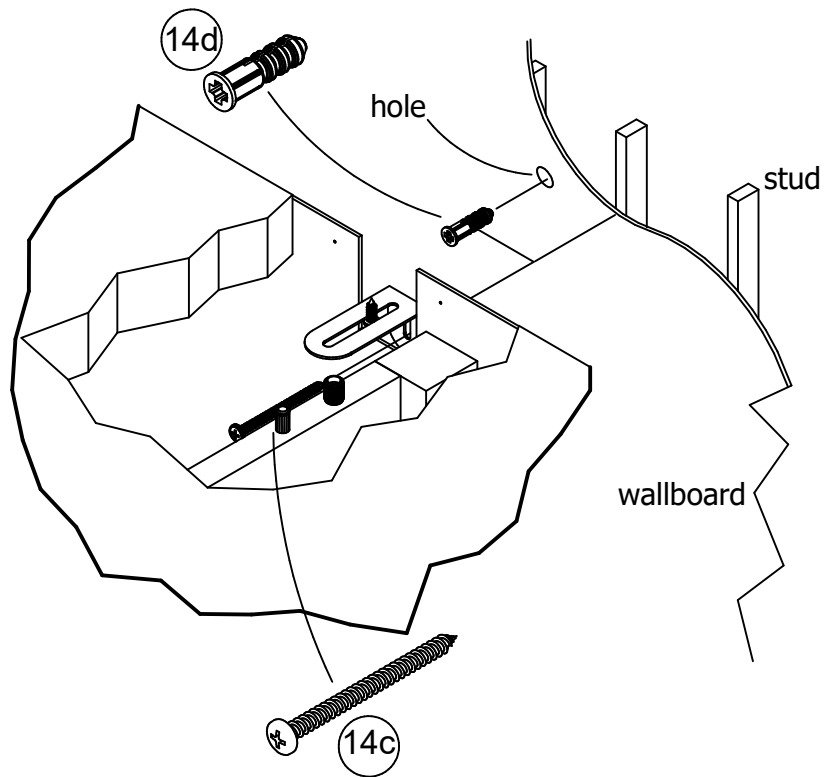

### OPTION 1: Attachment into a wall stud (preferred method)

Using a stud finder, locate a stud in the wall. Place your unit against the wall, with the safety bracket aligned in this location. To make driving the screw easier, you can drill a 1/8" diameter pilot hole (3mm) through the safety bracket into the stud. Drive the screw through the safety bracket into the wall stud. Tighten the screw that was not fully tightened in step 18.

### OPTION 2: Attachment into drywall

Locate your unit where desired against a wall and mark the wall through the safety bracket, then move your unit aside. Drill a 3/16" diameter hole (5mm) into the wallboard. Tap the wall anchor into the hole until it is flush. Move your unit into location and fasten the wall bracket to the wall anchor with the screw. Tighten the screw that was not fully tightened in step 18.

# STEP 24

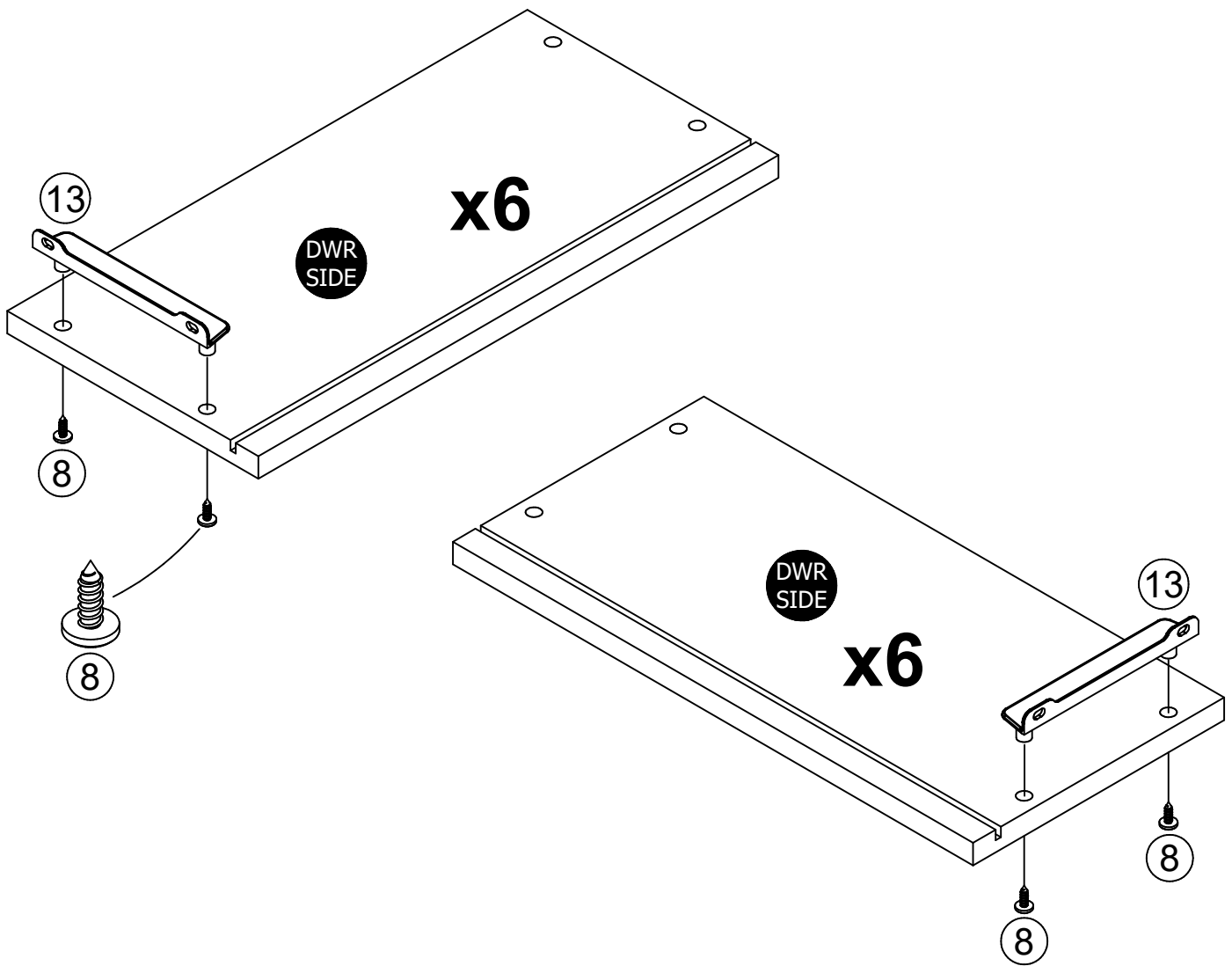
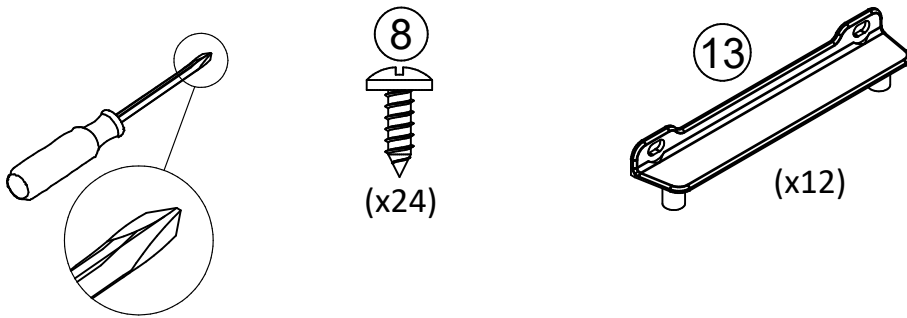



# STEP 25

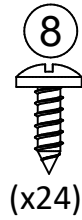
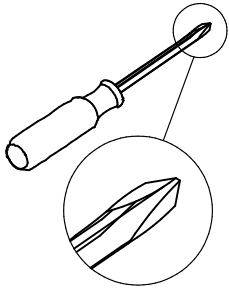

Be sure the groove in the drawer sides are centered with the in drawer front.

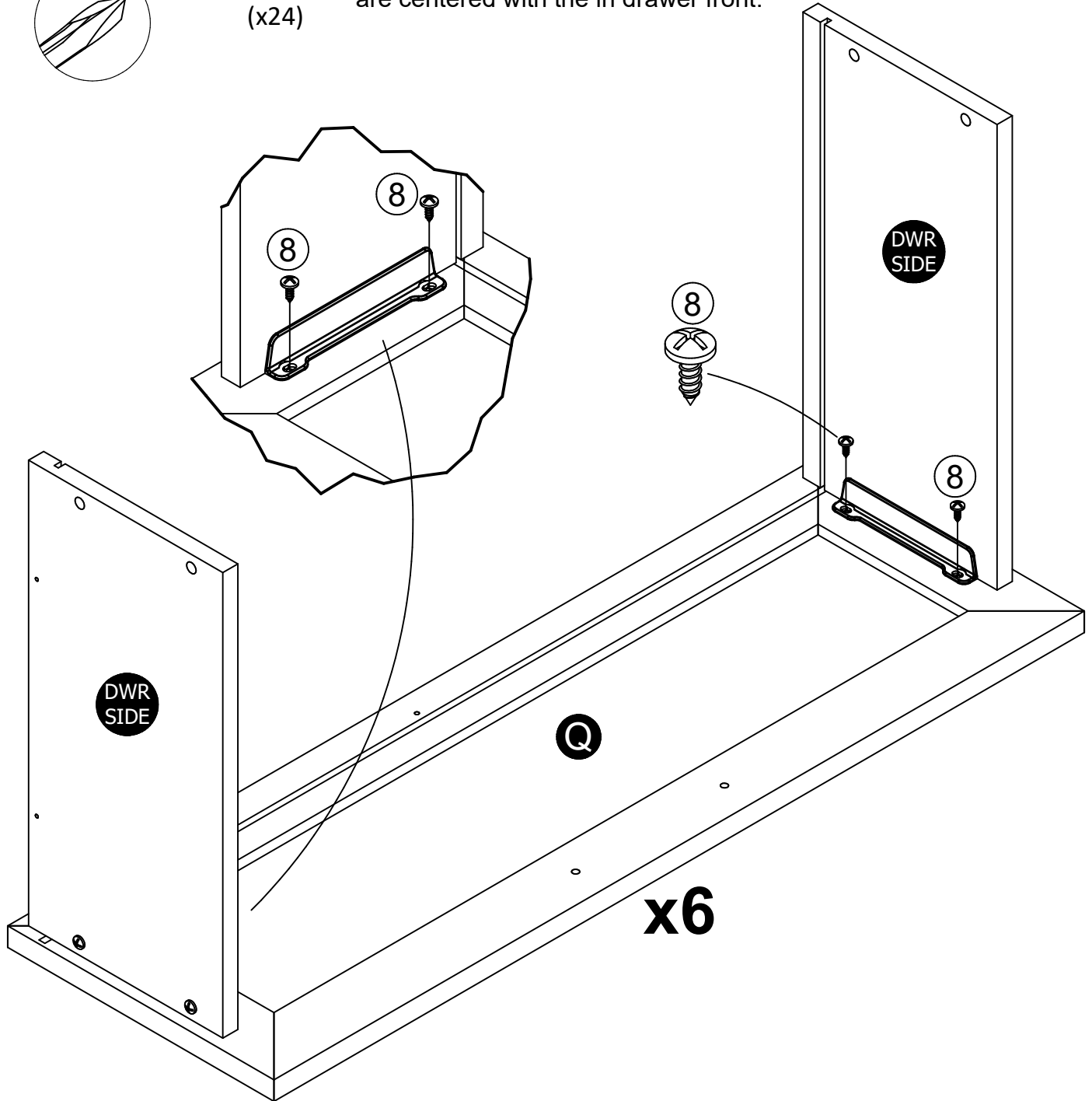

# STEP 26

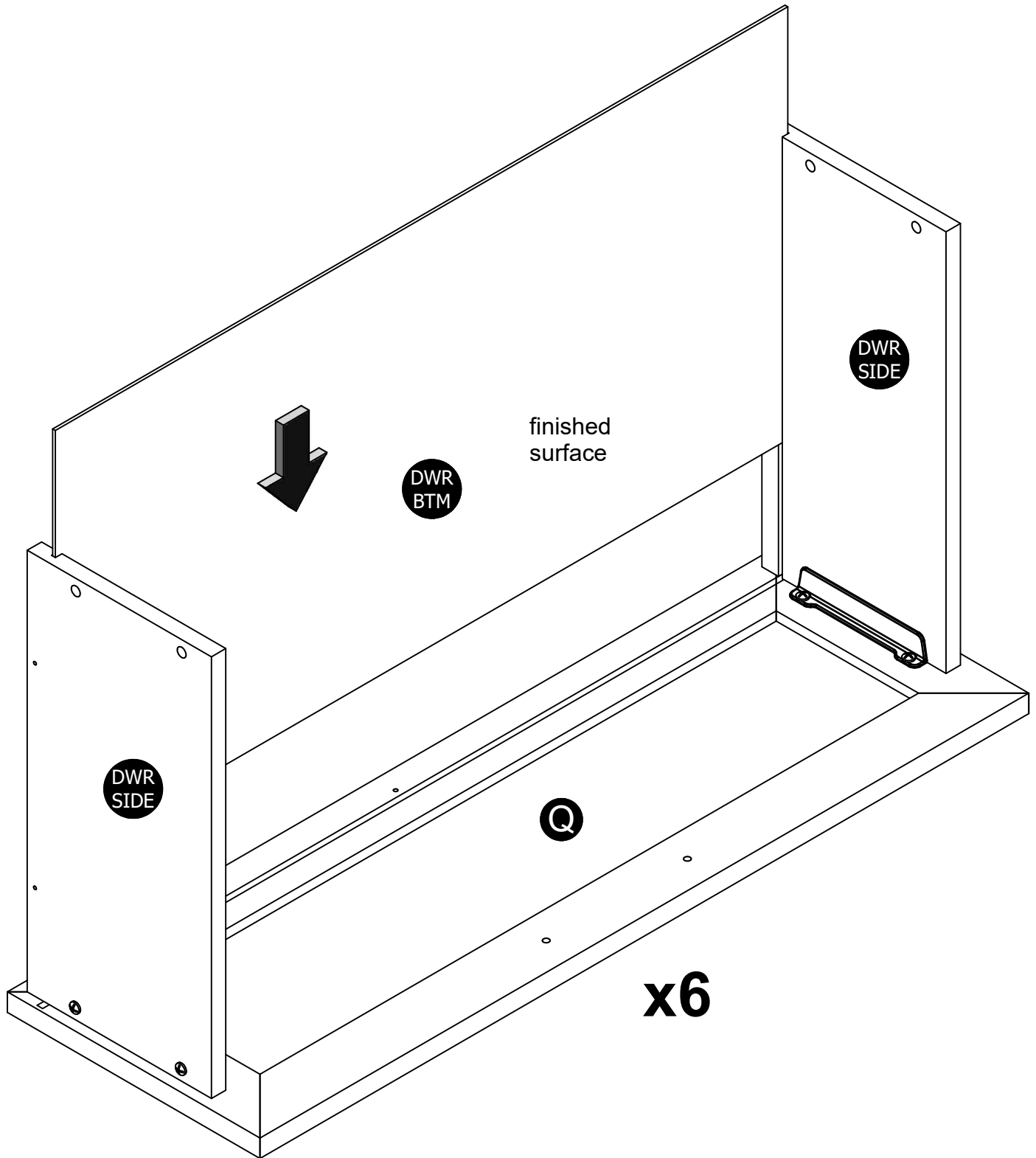

# STEP 27

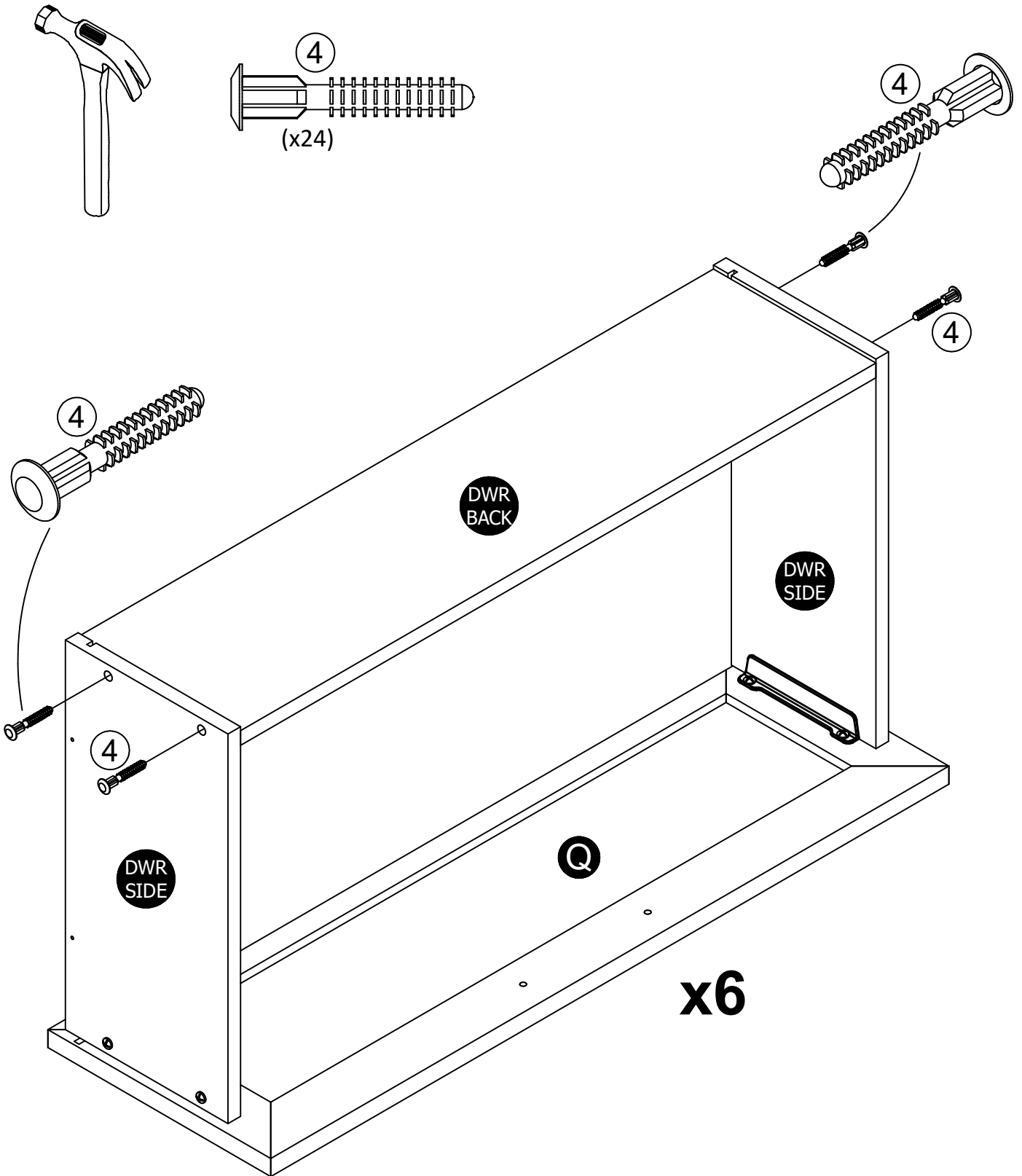

# STEP 28

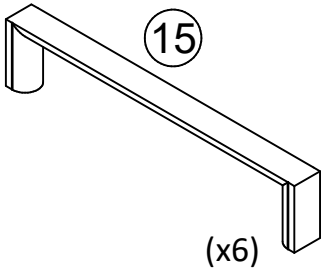
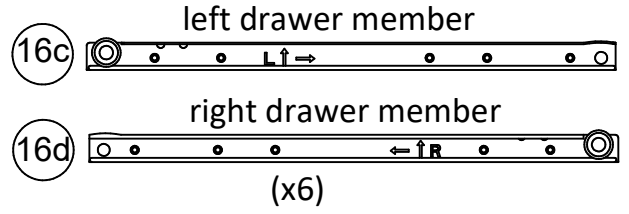
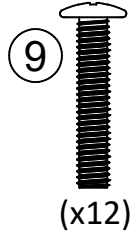
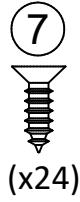
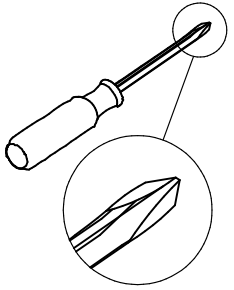

Attach the slides first and then the handle.

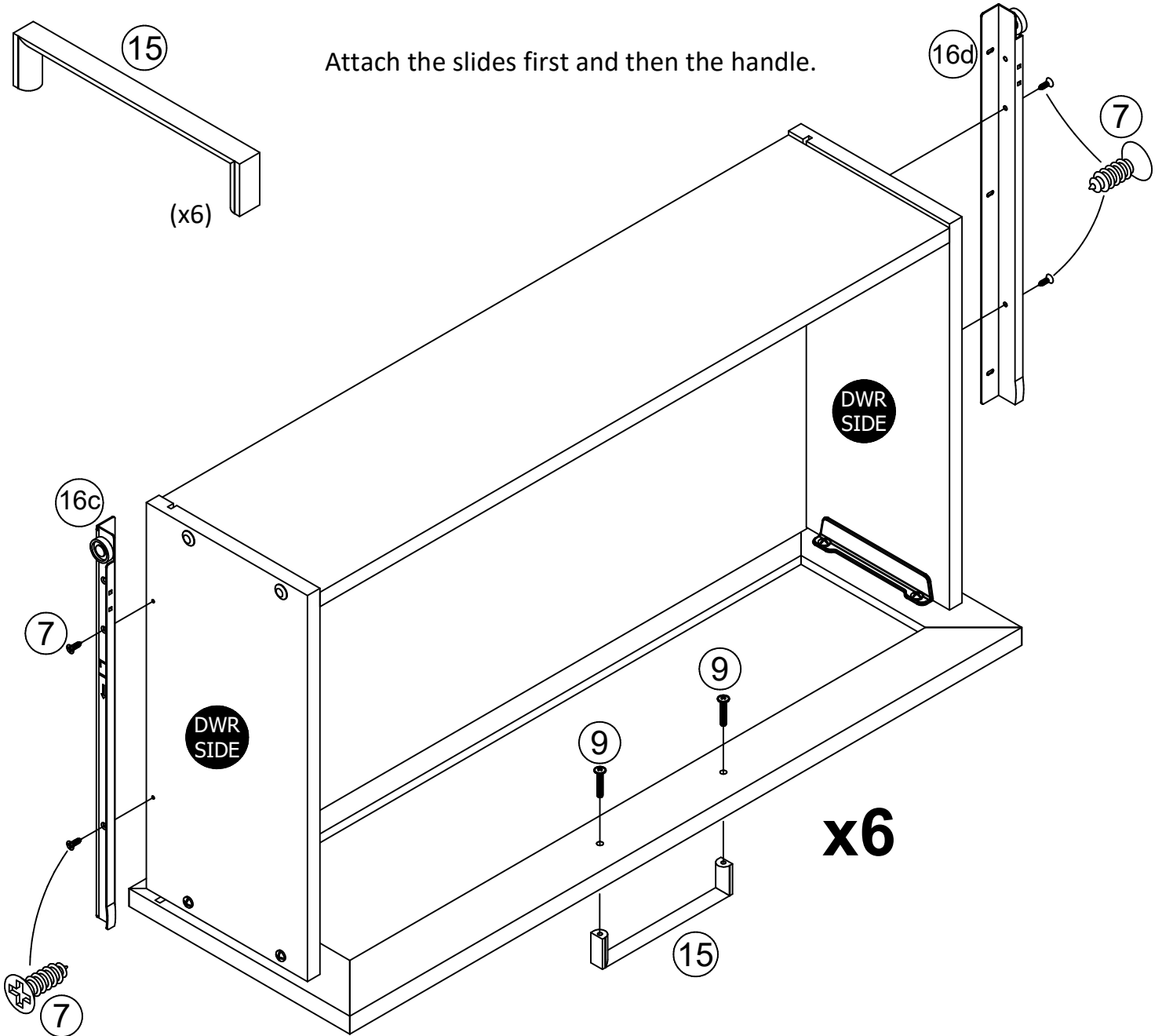

# STEP 29

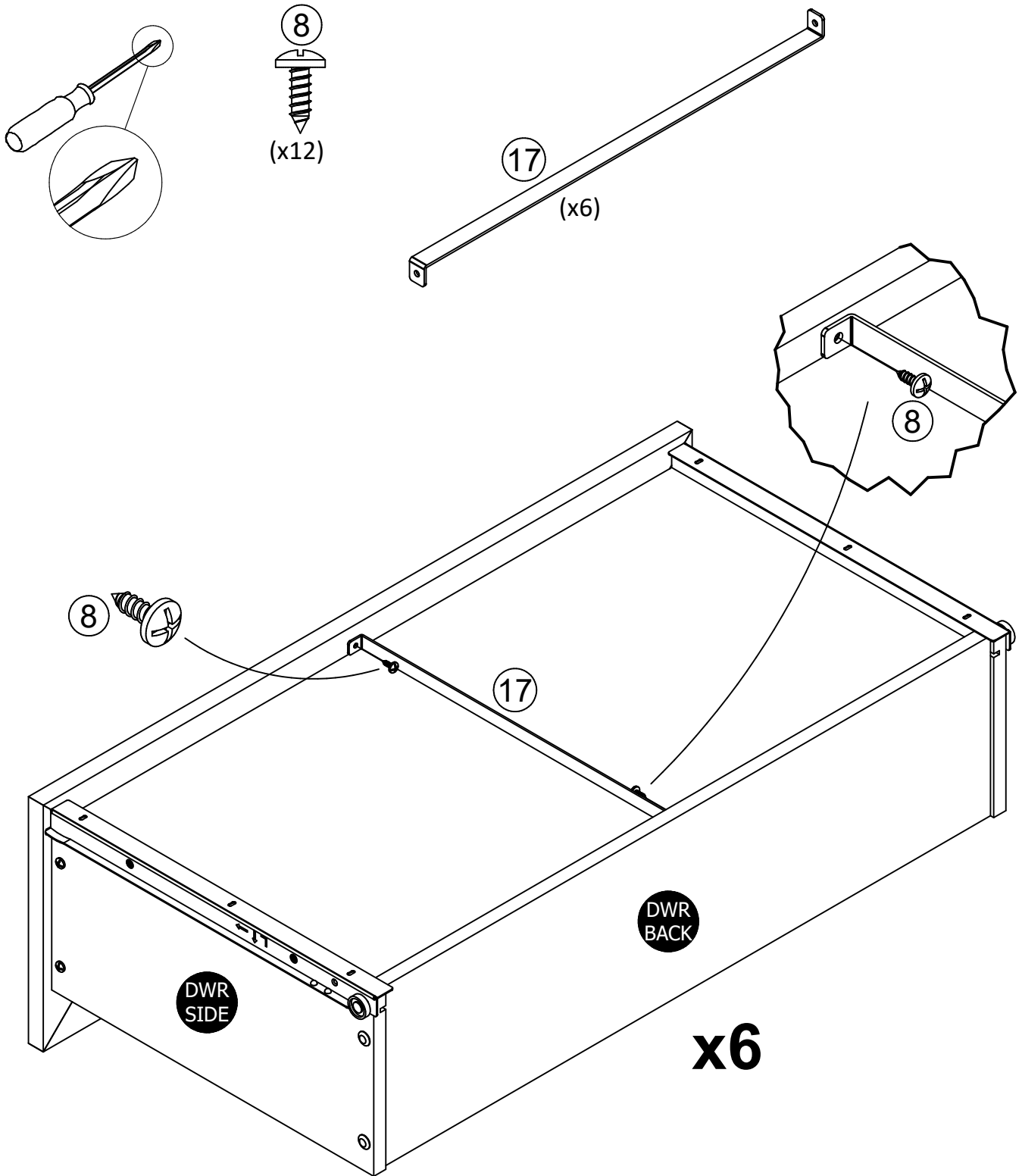

## STEP 30

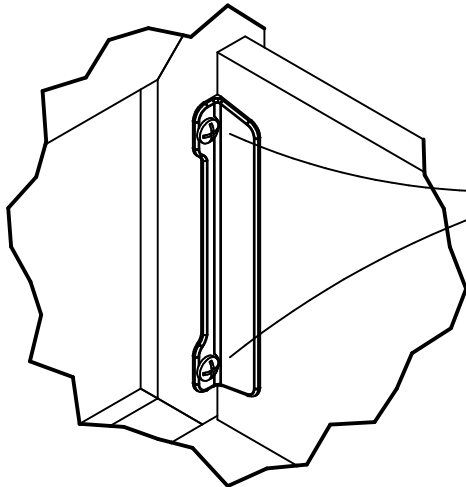

Note: The drawer bracket holes are slotted. Drawer fronts can be adjusted by loosening screws, making needed adjustments and retightening screws.

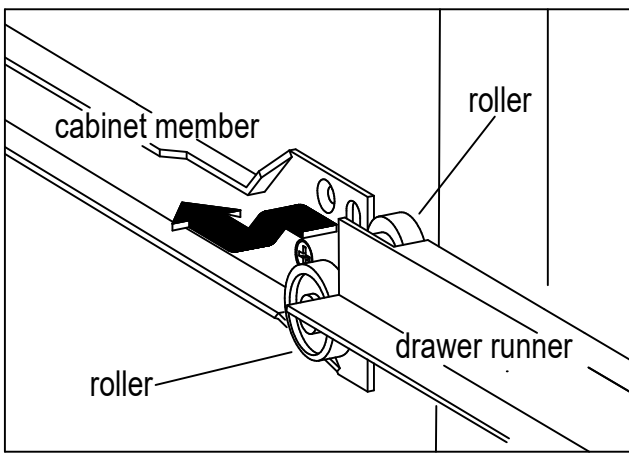
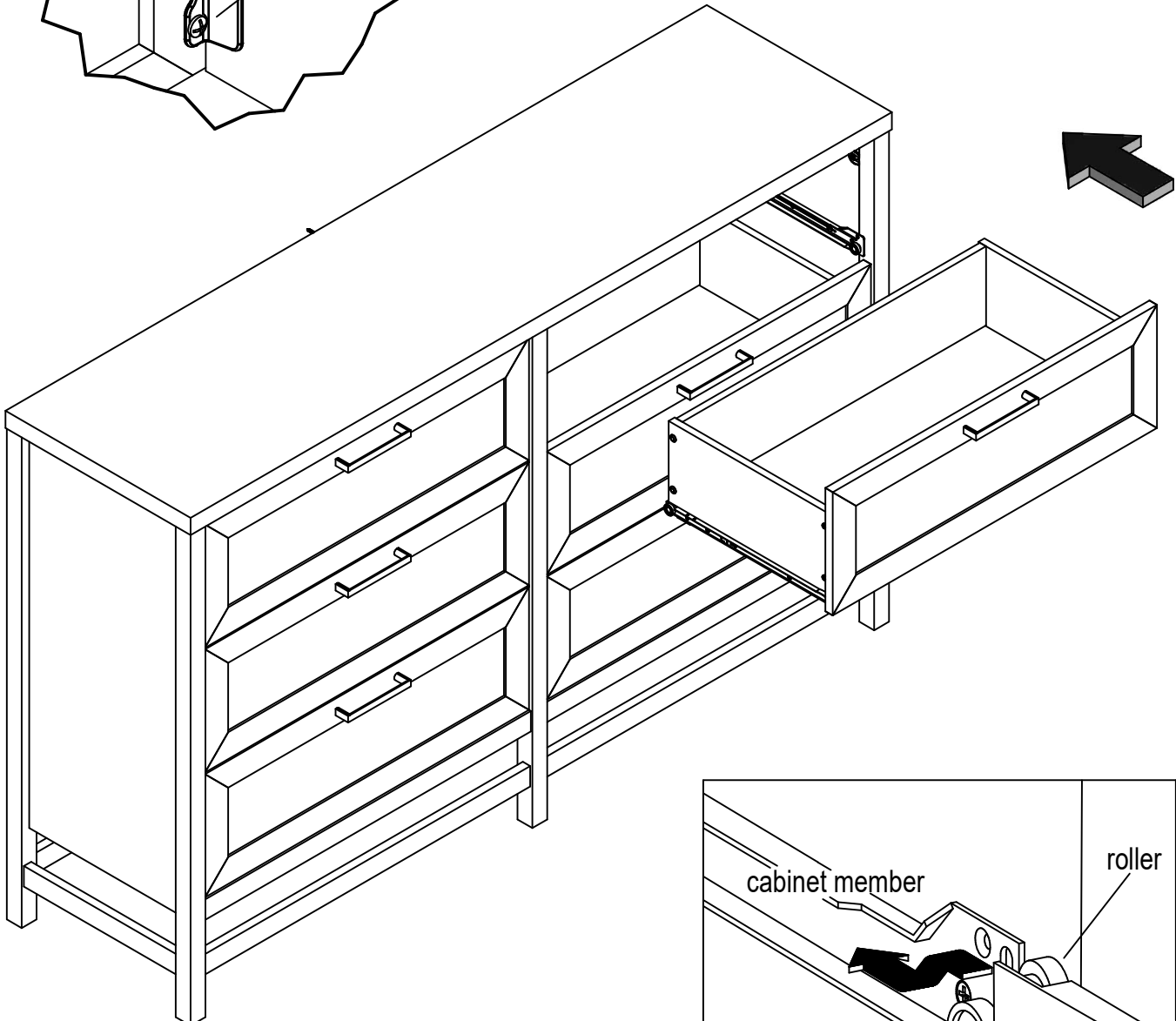

## Maximum Loads

This unit has been designed to support the maximum loads shown. Exceeding these load limits could cause sagging, instability, product collapse, and/or serious injury.

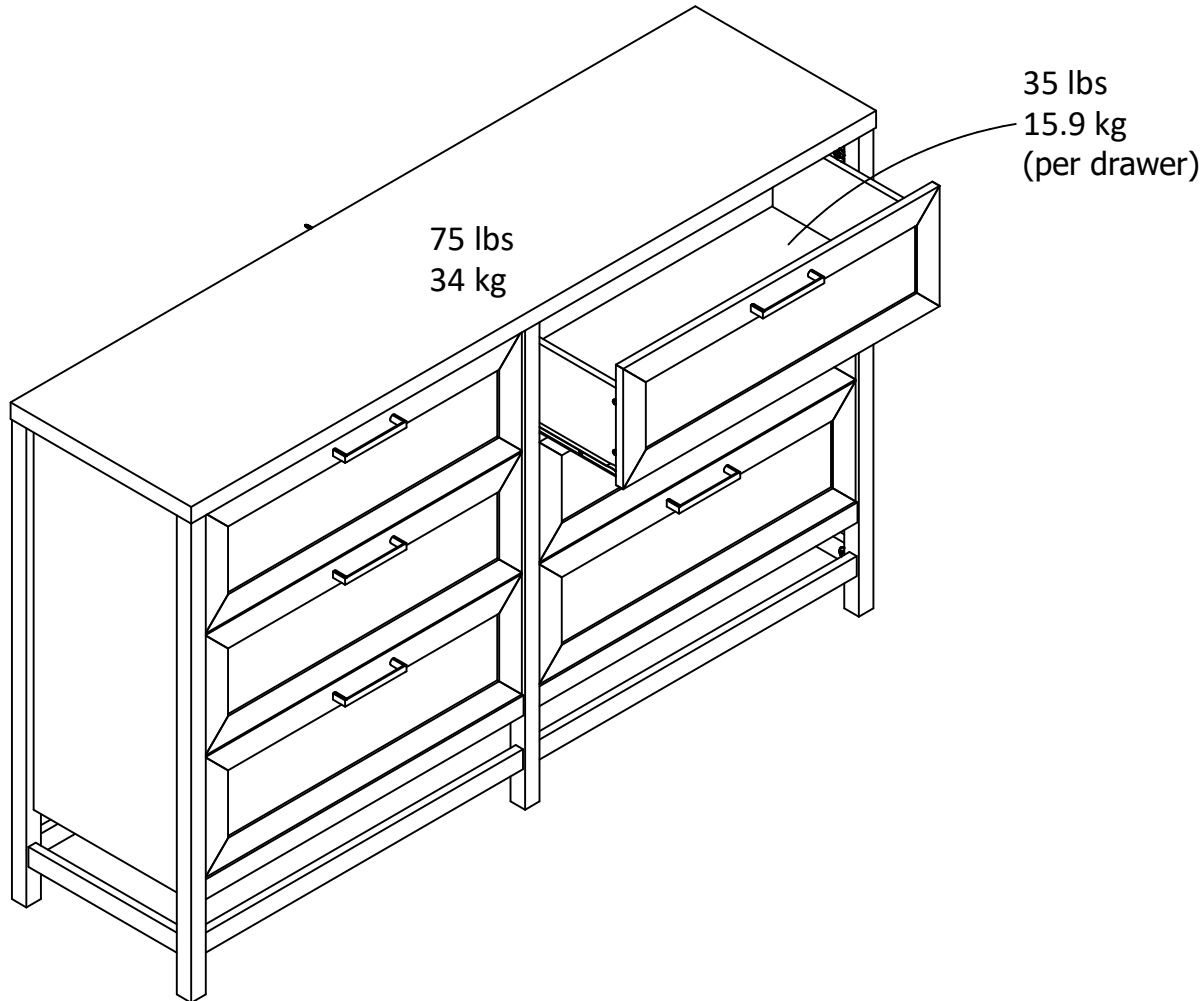

**Warning: Risk of injury to persons - do not place a television on this furniture. This furniture is not approved for use with a television.**

### Certificate of Conformity

1. This certificate applies to the Dorel Home Furnishings, Inc. product identified by this instruction manual.
2. This certificate applies to compliance of this product with the CPSC Ban on Lead-Containing Paint (16 CFR 1303).
3. This product is distributed by: Dorel Home Furnishings, Inc.  
410 East First Street South  
Wright City, MO 63390  
636-745-3351
4. Site of Manufacture: Tiffin OH
5. See front page of instruction manual for date of manufacture.

## Register your product to receive the following:



- \* New trend details - sneak peek on what's new
- \* Surveys - have a voice within our community
- \* Exclusive deals and discount codes
- \* Quick and easy replacement part service

To register your product, visit [ameriwoodhome.com](http://ameriwoodhome.com)

## *5 Star Rating*



Visit your local retailer's website, rate your purchased product and leave us some feedback!

We would like to extend a big "Thank You" to all of our customers for taking the time to assemble this Ameriwood Home product, and to give us your valuable feedback.

*Thank  
You!*



## Cubierta Delantera

Este libro de instrucciones contiene información **IMPORTANTE** de seguridad. Por favor lea y manténgalo para referencia en el futuro.

**No Regrese este producto!** Comuníquese con nuestro amistoso equipo de servicio al cliente para obtener ayuda.

Llámenos al: 1-800-489-3351 (Gratis) Lunes - Viernes 9am - 5pm CST

Visitar: [www.ameriwoodhome.com](http://www.ameriwoodhome.com)

## PRECAUCION

Este mueble puede volcarse y causar graves heridas y/o muerte.

Anclar el mueble a un poste de madera en la pared (si esto se requiere).

No Permita que los niños monten el mueble.

Mantenga los artículos más pesados en los cajones de abajo.

## Consejos Útiles (página 2)

- Abra su artículo en el área donde usted planea utilizarlo para evitar levantar y moverlo menos
- Identificar, ordenar y contar las piezas antes de intentar ensamblar
- Las clavijas de compresión se golpean con un martillo
- Las diapositivas están marcadas con una R (derecha) y L (izquierda) para la colocación correcta
- Asegúrese de que siempre este el punto localizado en la parte superior de bloqueador de leva este volteado hacia borde exterior
- Utilizar todos los clavos para el panel de atrás y distribuirlos por igual
- El panel de atrás debe utilizarse para asegurarse de que la unidad quede fija y firme
- No use químicas fuertes ni limpiadores abrasivos en este artículo
- Nunca empuje, tire ni arrastre los muebles

## Antes de Que Empieces (página 3)

- Lea cuidadosamente cada paso y siga el orden correcto
- Separar y contar todas sus piezas y hardware
- Dése suficiente espacio para el proceso de ensamble
- Tenga las siguientes herramientas: destornillador de cabeza plana, #2 cabeza Phillips  
Destornillador y martillo
- Precaución: Si usa un taladro electrónico o un destornillador eléctrico para atornillar, por favor asegúrese que deje de atornillar cuando el tornillo este apretado. Fallar hacer esto puede causar barrer el tornillo.

## Sistema de fijar el bloqueo de leva (página 3)

Esta sistema de fijar el bloqueo de leva sera usado en todo el proceso ensamble.

## **Página 10 / 13 / 16**

Deberá golpear el conector (6) con un martillo para insertarlo completamente. Asegúrese de que el conector está colocado como se muestra antes de golpear en el agujero.

## **Página 11 / 14 / 17**

Gire el tornillo en el sentido de las agujas del reloj para fijar las piezas en su sitio.

## **Página 23**

Ajuste los orificios del riel de la estantería (M) con los cierres rápidos (10) y presione hacia abajo. Gire el tornillo del cierre rápido en el sentido de las agujas del reloj para fijar las piezas en su sitio.

## **Página 26**

No apriete completamente el tornillo.

## **Página 28**

**¡IMPORTANTE! EL PANEL TRASERO ES UNA PARTE ESTRUCTURAL DE ESTA UNIDAD Y SE DEBE INSTALAR CORRECTAMENTE.**

Se acopla el panel posterior como se muestra clavando directamente en los bordes crudos a través de la parte superior e inferior y usando tornillos (8) para atornillar en la parte posterior de las piernas I y J.

Asegúrese de que nuestra unidad es cuadrada. La distancia de esquina a esquina debe ser igual, como se muestra.

Alinee el borde inferior del panel trasero con el borde inferior de la parte inferior izquierda (E) y la parte inferior derecha (F).

## **Página 30**

Gire el tornillo en el sentido de las agujas del reloj para encajar las piezas.

## **Página 31**

**Para mampostería, hormigón u otros materiales de pared:**

Consulte en su ferretería local los anclajes adecuados para fijar el soporte de seguridad.

**IMPORTANTE:** ESTA UNIDAD DEBE ESTAR FIJADA A LA PARED PARA EVITAR QUE SE VUELQUE. SIGA ESTAS INSTRUCCIONES PARA INSTALAR EL SOPORTE DE SEGURIDAD ANTIVUELCO SUMINISTRADO CON ESTE PRODUCTO.

## **ADVERTENCIA**

**Pueden producirse lesiones graves o mortales por aplastamiento debido al vuelco de los muebles.**

## Página 31

### Para evitar el vuelco:

- \* Instale el sistema de retención de vuelco provisto
- \* Coloque los artículos más pesados en los cajones más bajos
- \* A menos que esté específicamente diseñado para ello, no coloque televisores u otros objetos pesados en la parte superior de este producto
- \* Nunca permita que los niños trepen o se cuelguen de los cajones, la puerta o los estantes
- \* Nunca abra más de un cajón a la vez.

**El uso de dispositivos de sujeción para el vuelco solo puede reducir, pero no eliminar, el riesgo de vuelco**

### **OPCIÓN 1: Fijación en un montante de la pared (método preferido)**

Con la ayuda de un localizador de montantes, localice un montante en la pared. Coloque su unidad contra la pared, con el soporte de seguridad alineado en esta ubicación. Para facilitar la introducción del tornillo, puede taladrar un agujero piloto de 1/8 pulgadas (3 mm) de diámetro a través del soporte de seguridad en el montante. Introduzca el tornillo a través del soporte de seguridad en el montante de la pared. Apriete el tornillo que no se haya apretado del todo en el paso 18.

### **OPCIÓN 2: Fijación en la placa de yeso laminado**

Coloque su unidad en el lugar deseado contra una pared y marque la pared a través del soporte de seguridad, luego mueva su unidad a un lado. Perfore un agujero de 3/16 pulgadas (5 mm) de diámetro en la pared. Golpee el anclaje de pared en el agujero hasta que quede al ras. Mueva su unidad a su ubicación y fije el soporte de pared al anclaje de pared con el tornillo. Apriete el tornillo que no se apretó del todo en el paso 18.

## Página 33

Asegúrese de que la ranura en los lados del cajón esté centrada en el frente del cajón.

## Página 36

Fije primero las guías y luego el asa.

## Página 38

Nota: Los agujeros de los soportes de los cajones están ranurados. Los frentes de los cajones pueden ajustarse aflojando los tornillos, realizando los ajustes necesarios y volviendo a apretar los tornillos.

## **Página 39**

### **CARGA MAXIMA**

Esta unidad ha sido diseñada para soportar la carga máxima anotada. El exceder estos límites puede causar inestabilidad, colapsarse y/o causar serias lesiones.

**ADVERTENCIA:** Riesgo de lesiones a las personas - no coloque un televisor sobre muebles. Este mueble no está aprobado para su uso con un televisor.

## **Página 40**

Registre su producto para recibir lo siguiente:

- \* Detalles de nuevas tendencias - Vistazo a lo nuevo
- \* Encuestas - alec su voz entre su comunidad
- \* Códigos de ofertas y descuentos exclusivos
- \* Fácil y rápido servicio de partes de remplace

Para registrar su producto, visite [ameriwoodhome.com](http://ameriwoodhome.com)

Clasificación de 5 estrellas

Visite el sitio web de su tienda local, califique su comprado y denos sus comentarios!

Nos gustaría enviar un gran "Agradecimiento" a todos nuestros clientes por tomarse el tiempo de ensamblar este producto de Ameriwood Home, y por darnos sus valiosos comentarios.

Gracias

## Couverture Avant

CE LIVRET D'INSTRUCTION CONTIENT DES INFORMATIONS **IMPORTANTES** SUR LA SÉCURITÉ. VEUILLEZ LIRE ET GARDER POUR UNE RÉFÉRENCE FUTURE

**Ne retournez pas ce produit!** Contactez notre équipe de service à la clientèle amicale d'abord pour obtenir de l'aide.

**Appelez-nous:** 1-800-489-3351 (sans frais) du Lundi au Vendredi de 9h à 17h Heure Centrale

**Visitez:** [www.ameriwoodhome.com](http://www.ameriwoodhome.com)

## ATTENTION

Le meuble peut basculer et causer des blessures graves ou la mort.

Ancrer le meuble à une planche murale dans le mur (si indiqué).

Ne laissez pas les enfants grimper sur le meuble.

Placez les articles lourds sur les étagères ou dans les tiroirs inférieurs.

## Astuces Utiles (page 2)

-Ouvrez votre article dans la zone que vous prévoyez de le garder pour moins de levage lourd

-Identifier, trier et compter les pièces avant d'essayer d'assembler

-Les goujons de compression sont taraudés avec un Marteau

-Les glissières sont marquées d'un R (droit) et d'un L (gauche) pour un bon placement

-Assurez-vous toujours de faire face la pointe situé sur le haut de la Serrure de Came vers le bord extérieur

-Utiliser tous les clous fournis pour le panneau arrière et les répartir également

-Le panneau arrière doit être utilisé pour vous assurer que votre appareil est robuste

-N'utilisez pas de produits chimiques agressifs ou de nettoyeurs abrasifs sur cet appareil

-Ne jamais pousser, tirer, ou faire glisser votre meuble

## Avant de Commencer (page 3)

-Lisez attentivement chaque étape et suivez le bon ordre

-Séparez et comptez toutes vos pièces et matériaux

-Donnez-vous suffisamment de place pour l'assemblage

-Avoir les outils suivants: tournevis à tête plate, #2 tournevis Phillips, et Marteau

-Attention: Si vous utilisez une perceuse électrique ou un tournevis électrique pour visser, veillez à ralentir et arrêter lorsque la vis est bien serrée. Le non-respect de cette consigne peut endommager la vis.

## Système de Fixation de Came (page 3)

Ce Système de Fixation de Came sera utilisé tout au long de l'assemblage

## Page 10 / 13 / 16

Vous devrez taper sur le connecteur (6) avec un marteau pour l'insérer complètement. Assurez-vous que le connecteur est positionné comme indiqué avant de le taper dans le trou.

## Page 11 / 14 / 17

Tournez la vis dans le sens des aiguilles d'une montre pour verrouiller les pièces en place.

## Page 23

Alignez les trous du rail de l'étagère (M) avec les verrous rapides (10) et appuyez dessus. Tourner la vis du verrou rapide dans le sens des aiguilles d'une montre pour verrouiller les pièces en place.

## Page 26

Ne pas serrer complètement la vis.

## Page 28

**IMPORTANT! LE PANNEAU ARRIÈRE EST UN ÉLÉMENT STRUCTUREL DE CETTE UNITÉ ET DOIT ÊTRE INSTALLÉ CORRECTEMENT.**

Attaché le panneau arrière comme indiqué clouage directement dans les bords bruts à travers le haut et le bas et à l'aide de vis (8) pour visser à l'arrière des jambes I et J.

Assurez-vous que notre unité est carrée. La distance d'un coin à l'autre doit être égale, comme indiqué.

Alignez le bord inférieur du panneau arrière avec le bord inférieur du fond gauche (E) et du fond droit (F).

## Page 30

Tournez la vis dans le sens des aiguilles d'une montre pour verrouiller les pièces ensemble.

## Page 31

**Pour la maçonnerie, le béton ou d'autres matériaux muraux :**

Consultez votre quincaillerie locale pour obtenir des ancrages appropriés afin de fixer solidement le support de sécurité.

**IMPORTANT :** CET APPAREIL DOIT ÊTRE FIXÉ AU MUR POUR ÉVITER TOUT BASCULEMENT. SUIVEZ CES INSTRUCTIONS POUR INSTALLER LE SUPPORT DE SÉCURITÉ ANTI-BASCULEMENT FOURNI AVEC CE PRODUIT.

### AVERTISSEMENT

**Le basculement d'un meuble peut entraîner des blessures graves ou mortelles par écrasement.**

## Page 31

### **Pour éviter le basculement :**

- \* Installer le dispositif de retenue en cas de basculement fourni
- \* Placez les articles les plus lourds dans les tiroirs les plus bas
- \* Ne posez pas de téléviseurs ou d'autres objets lourds sur le dessus de ce produit, à moins qu'ils ne soient spécifiquement conçus pour cela.
- \* Ne permettez jamais aux enfants de grimper ou de s'accrocher aux tiroirs, aux portes ou aux étagères
- \* N'ouvrez jamais plus d'un tiroir à la fois

**L'utilisation de dispositifs de retenue en cas de basculement ne peut que réduire, mais pas éliminer, le risque de basculement.**

### **OPTION 1 : Fixation dans un montant de mur (méthode préférée)**

À l'aide d'un détecteur de montants, localisez un montant dans le mur. Placez votre appareil contre le mur, avec le support de sécurité aligné à cet endroit. Pour faciliter l'insertion de la vis, vous pouvez percer un trou pilote de 1/8 de pouce de diamètre (3 mm) à travers le support de sécurité dans le montant. Enfoncez la vis à travers le support de sécurité dans le montant du mur. Serrez la vis qui n'a pas été entièrement serrée à l'étape 18.

### **OPTION 2 : Fixation dans les cloisons sèches**

Placez votre appareil à l'endroit souhaité contre un mur et marquez le mur à travers le support de sécurité, puis mettez votre appareil de côté. Percez un trou de 3/16 de pouce de diamètre (5 mm) dans le panneau mural. Tapez sur l'ancrage mural dans le trou jusqu'à ce qu'il soit affleurant. Mettez votre appareil en place et fixez le support mural à l'ancrage mural à l'aide de la vis. Serrez la vis qui n'a pas été entièrement serrée à l'étape 18.

## Page 33

Assurez-vous que la rainure des côtés du tiroir est centrée avec l'avant du tiroir.

## Page 36

Fixez d'abord les glissières, puis la poignée.

## Page 38

Remarque : Les trous des supports de tiroir sont fendus. Les façades des tiroirs peuvent être ajustées en desserrant les vis, en effectuant les ajustements nécessaires et en resserrant les vis.

## Page 39

### CHARGES MAXIMALES

Ce meuble a été conçu pour supporter les charges maximales indiquées. En excédant ces limites de charge, le meuble pourrait devenir instable, s'effondrer, et/ou causer des blessures graves.

AVERTISSEMENT : Risque de blessure corporelle - ne pas placer une télévision sur ce meuble. Ce meuble n'est pas approuvé pour une utilisation avec une télévision.

## Page 40

Enregistrez votre produit pour recevoir les éléments suivantes:

- \* Détails sur les nouvelles tendances - un aperçu sur les nouveautés
- \* Sondages - avoir une voix au sein de notre communauté
- \* Offres exclusives et codes promo
- \* Service de pièces de rechange rapide et facile

Pour enregistrer votre produit, visitez [ameriwoodhome.com](http://ameriwoodhome.com)

5 Étoiles

Visitez le site Web de votre détaillant local, évaluez votre produit acheté et laissez-nous quelques commentaires !

Nous tenons à offrir un grand "Merci" à tous nos clients pour avoir pris le temps d'assembler ce produit "Ameriwood Home", et de nous donner vos commentaires précieux.

Merci